



USERS MANUAL

LC24-20 MULTI-FONT

DOT MATRIX PRINTER

Self Declaration

Radio interference regarding this equipment has been eliminated according to Vfg 1046/1984 announced by the DBP.

DBP has been informed of the introduction of this special equipment and has been granted the right to examine the whole series.

It is the user's responsibility to see that his own assembled system is in accordance with the technical regulations under Vfg 1046/1984.

To conform to FTZ-regulations it is necessary to make all connections to the printer with shielded cable.

The equipment may only be opened by qualified service representatives.

The above statement applies only to printers marketed in Germany.

Trademark Acknowledgements

LC24-20, LC24-200, LC24-10, SF-10DS, PT-10ZS, RC-32Z, DC-32Z, SPC-8K: Star Micronics Co., Ltd.

IBM-PC, PS/2, PC-AT, Proprinter X24E, Proprinter 24P, PS/1 printer, PC-DOS: International Business Machines Corp.

MS-DOS, Microsoft BASIC: Microsoft Corporation

LQ-860, LQ-850: Seiko Epron Corp.

NOTICE

- All rights reserved. Reproduction of any part of this manual in any form whatsoever without STAR's express permission is forbidden.
- The contents of this manual are subject to change without notice.
- All efforts have been made to ensure the accuracy of the contents of this manual at the time of press. However, should any errors be detected, STAR would greatly appreciate being informed of them.
- The above notwithstanding, STAR can assume no responsibility for any errors in this manual.

HOW TO USE THIS MANUAL

This manual is organized into eleven chapters. To learn how to make the best use of your printer you are urged to read through chapters 1 through 6. Chapters 7 through 11 may be treated as a reference guide for programming operations, etc. It assumes a degree of knowledge of the operation of computers. The chapters are as follows:

Chapter 1 — Introduction

This chapter indicates the primary features of your printer, the names and functions of the printer components, and an actual example of the many font styles that your printer can produce.

Chapter 2 — Setting Up the Printer

This chapter explains how to get the printer unpacked and set up. Read this chapter before you do anything else.

Chapter 3 — Paper Installation and Use

This chapter describes the instructions for printing such as selecting paper types, adjusting the printing gap, and installing paper.

Chapter 4 — Control Panel Operations

There are a number of controls on the front panel which perform various functions related to paper handling, print modes and font selection. After performing the setup of the printer, read this chapter and try out the procedures to find out how the printer works.

Chapter 5 — Default Settings - EDS mode

This chapter explains how to set the Electronic DIP Switch (EDS) mode to make your printer match your system and software needs.

Chapter 6 — Troubleshooting

This section shows a list of check points to follow if your printer is not working properly. It also includes details of some routine maintenance operations you can perform yourself. It is not, however, a complete service manual. Call your authorized service center if you are unsure of your ability to carry out any maintenance or servicing operations on the printer.

Chapter 7 — Optional Accessories

This chapter explains the optional accessories that are available for your printer, and how to install and use them.

Chapter 8 — Printer Control Commands

This chapter explains the different emulations provided by your printer, and the software commands that are used to drive it. This section is of use if you are writing or modifying programs to take advantage of the printer's features.

Chapter 9 — Download Characters

This chapter explains the procedures to create your own characters.

Chapter 10 — MS-DOS and Your Printer

Since the PS/2 or PC-AT family of computers running under MS-DOS is currently the most popular configuration of microcomputer, we have included a few hints and tips to help you use your printer with such systems. Since virtually all PCs are sold with a Microsoft BASIC interpreter, we have also included some hints, and a sample program in this language to demonstrate the capabilities of the printer.

Chapter 11 — Reference

This section provides references for your printer, such as specifications, the pinout of interface connector, and the character tables.

The character table charts give the different character sets available.

TABLE OF CONTENTS

Chapter 1 INTRODUCTION	1
Printer components	2
Summary of printer features	4
Font style example	6
Chapter 2 SETTING UP THE PRINTER	9
Printer placement	9
Unpacking and inspection	10
Setting up	12
Installing the platen knob	12
Removing the front cover	13
Installing the ribbon cartridge	14
Installing the front cover	15
Installing the paper guide	16
Installing the mute cover	16
Connecting the interface cable	17
Configuring your software for the printer	18
Chapter 3 PAPER INSTALLATION AND USE	19
Selection of paper	19
Adjusting the printing gap	21
Loading fanfold forms	22
Loading the paper	23
Paper parking	26
Paper unparking	27
Tear off function	27
Loading single sheets	28
Chapter 4 CONTROL PANEL OPERATIONS	31
Button and indicator functions	31
ON LINE	32
PAPER FEED	32
EJECT/PARK	33
PITCH	33
FONT	34
Power-up functions	35
Short test mode	35
Long test mode	36
Print area test mode	37

Pitch lock mode	37
Font lock mode	37
Font and Pitch lock mode	37
Dot adjustment mode	38
Hexadecimal dump	40
Switch combination functions	41
Form feed	41
Top of form	41
Forward micro-feed	42
Reverse micro-feed	42
Changing the auto loading position	42
Clearing the buffer/All reset	43
Save macro definition	43
Condition indicated by messages and tones	45
Summary of display messages	45
Summary of beep tones	47
Chapter 5 DEFAULT SETTINGS-EDS MODE	49
How to set the EDS mode	49
Functions of the EDS settings	50
Chapter 6 TROUBLESHOOTING	57
Chapter 7 OPTIONAL ACCESSORIES	65
Automatic Sheet Feeder	65
Setting up	66
Loading paper	68
Feeding a single sheet	70
Pull Tractor Unit	71
Setting up	71
Loading paper	73
Font Cartridges and RAM Cartridges	75
Interface Converter	78
DIP switch functions on the Converter	79
Chapter 8 PRINTER CONTROL COMMANDS	81
Font control commands	82
Character set commands	87
Character size and pitch commands	90
Vertical position commands	96

Vertical position commands	96
Horizontal position commands	104
Graphics commands	109
Download character commands	113
Other printer commands	117
Chapter 9 DOWNLOAD CHARACTERS	121
Defining your own characters with Standard mode	121
Assigning the character data	122
Assigning a value of character space	123
Sample program	124
Defining your own characters with IBM mode	126
Assigning the download character set	126
Assigning the character dot pattern	127
Assigning the Index Table data	129
Sample program	130
Chapter 10 MS-DOS AND YOUR PRINTER	133
Programming the printer with DOS commands	133
Programming with BASIC	136
Chapter 11 REFERENCE	143
Specifications	143
Pinout of interface connector	147
Parallel interface	147
Serial interface	148
Character sets	149
Standard character set #2	150
International character sets	152
IBM character set #2	153
Character set #1	160
IBM special character set	161
Proportional spacing table	162
INDEX	173
COMMAND SUMMARY	177



Chapter 1

INTRODUCTION

This printer has a full complement of features, making it an excellent partner for a personal computer. It supports the Epson/IBM printer commands and character sets, enabling it to print just about anything your computer can generate, both text and graphics.

The selection of paper you can use is as varied as the types of documents you can produce. This printer accepts any of the following papers:

- Single sheets (cut forms) and stationery
- Fanfold forms (continuous forms)
- Multi-part forms
- Preprinted forms
- Labels.

This Multi-font printer has the following resident (internal) fonts which you can print:

- Draft
- Sanserif
- Script
- High-Speed Draft
- Courier
- Roman
- Prestige

In addition, you can print wide variation of fonts by using optional Font Cartridges.

The control panel has five buttons and one LCD display. The LCD displays and beep tones provide immediate, easy to understand feedback when you press the buttons on the control panel.



The five buttons can operate in combinations to perform a surprising variety of functions, including saving a macro.

The Paper Parking function enables you to keep fanfold forms parked in readiness while printing on single sheet paper.

To get acquainted with the printer's components and capabilities, refer to the information on the pages that follow.

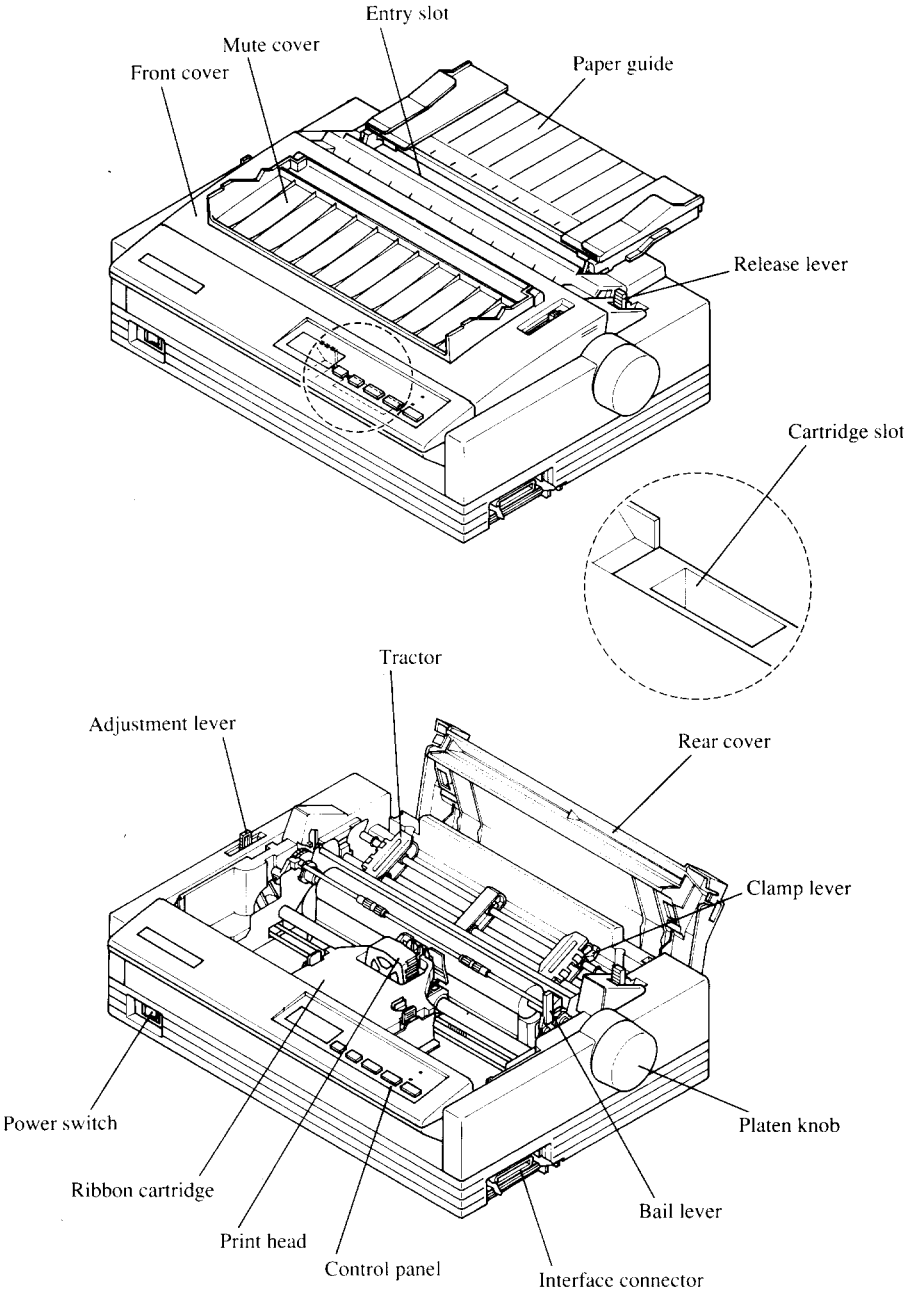
PRINTER COMPONENTS



Component	Description
Paper guide	Aligns single sheets (cut forms) to help the printer detect when paper is inserted.
Release lever	Releases pressure on the paper. This lever must be back for cut-sheet forms (), and forward for fanfold forms ().
Front cover	Protects the print head and other internal components of your printer.
Mute cover	Reduces the printing noise.
Rear cover	Protects the tractor feed unit and separates incoming and outgoing fanfold forms.
Entry slot	For inserting single sheets of paper.
Control panel	Indicates printer status and makes various control of printer functions simple and convenient.
Power switch	Switches power on or off.
Platen knob	Advances the paper manually.
Interface connector	Connects the computer to the printer.
Cartridge slot	Holds the optional Font cartridge or RAM cartridge.
Print head	Has a high resolution dot matrix (24-wire) composition for outstanding print quality.
Ribbon cartridge	Contains the printer ribbon.
Adjustment lever	Controls print darkness by adjusting for the thickness of forms being printed.
Tractors	Control the movement of fanfold forms.
Clamp lever	Clamps the tractor in place.
Bail lever	Opens and closes the paper bail which holds the paper against the platen. This lever is also used to load paper and to perform the short tear off function.



SUMMARY OF PRINTER FEATURES

Feature	Function
Dot matrix (24-wire) impact printing	High-Speed Draft, Draft and Letter-Quality printing.
Extensive software support	It is compatible with the Epson and IBM standard, and works with any software that supports those printers.
AEC mode	Auto Emulation Change (AEC) mode is provided to select the proper emulation mode automatically sent from your program.
Multi-font support	This printer includes HS-Draft, Draft, Roman, Sanserif, Courier, Prestige, and Script fonts. In addition, you can print wide variation of fonts by using optional Font Cartridges.
Carriage size	A standard carriage that prints on fanfold forms up to 254 mm (10 inches) wide and cut forms up to 279.4 mm (11 inches) wide.
Multi-speed printing	<p>In High-Speed Draft mode, prints at speed up to:</p> <ul style="list-style-type: none"> • 210 CPS (Characters per second) in 10 pitch (CPI). <p>In Draft mode, prints at speeds up to:</p> <ul style="list-style-type: none"> • 240 CPS in 15 pitch • 192 CPS in 12 pitch • 160 CPS in 10 pitch <p>In Letter-Quality mode, prints at speeds up to:</p> <ul style="list-style-type: none"> • 80 CPS in 15 pitch • 64 CPS in 12 pitch • 53 CPS in 10 pitch.

Feature	Function
Character spacing	Prints in 10, 12, 15, 17, 20, and 24 CPI, as well as proportional spacing.
LCD Control panel	Button control for fonts, pitches, paper movement, and paper park functions. LCD messages indicate current status.
Font/Pitch Lock	Ignores font and pitch selections sent from your computer, and stays on the selected font and pitch with the control panel.
Quiet mode	Reduces printing noise by approximately 50%. However, printing speed is also reduced.
Graphics printing	Standard graphics printing with resolution of up to 360 × 360 dots per square inch. It also supports the NEC graphics commands.
Paper parking	Parks fanfold paper. You can print on cut sheet paper without unloading the fanfold forms.
Print styles	<p>Highlighting capability with the following emphasis styles:</p> <ul style="list-style-type: none"> • Double-high • Double-strike • Double-wide • Emphasized • Italics • Outline • Overlining • Quadruple-high • Quadruple-wide • Shadow • Subscript • Superscript • Underlining.
Tear off function	Fanfold forms can be torn off without advancing blank forms.
Multi-part forms	Prints up to three-part forms.
Ribbon cartridge	Contains the printer ribbon.
EDS mode	Electronic DIP Switch (EDS) mode allows you to easily change the default settings of your printer to match your system and software needs.

FONT STYLE EXAMPLE

The following example shows the many font styles your printer can print.

RESIDENT:	HS-Draft	123456789	ABCDE	abcde
	Draft	123456789	ABCDE	abcde
	Roman	123456789	ABCDE	abcde
	Sanserif	123456789	ABCDE	abcde
	Courier	123456789	ABCDE	abcde
	Prestige	123456789	ABCDE	abcde
	Script	123456789	ABCDE	abcde
FC-1Z:	Orator	123456789	ABCDE	ABCDE
	Orator-2	123456789	ABCDE	abcde
	Letter Gothic	123456789	ABCDE	abcde
	Blippo	123456789	ABCDE	abcde
	Cinema	123456789	ABCDE	abcde
FC-2Z:	OCR-B	123456789	ABCDE	abcde
	OCR-A	123456789	ABCDE	abcde
	CODE 39			
	UPC/EAN	123456789	12345	
FC-3Z:	TW-Light	123456789	ABCDE	abcde
	H-Gothic	123456789	ABCDE	abcde
	Orane	123456789	ABCDE	abcde
FC-5Z:	Old Style	123456789	ABCDE	abcde
	Firenze	123456789	ABCDE	abcde
FC-10Z:	SLQ Script	123456789	ABCDE	abcde
FC-11Z:	SLQ Roman	123456789	ABCDE	abcde
FC-12Z:	SLQ TW-Light	123456789	ABCDE	abcde

Resident LQ fonts are:

Roman characters, Sanserif characters,
Courier characters, Prestige characters,
Script characters.

Print pitches are:

Pica pitch (10 CPI), Elite pitch (12 CPI),
Semi-condensed pitch (15 CPI), Condensed pica pitch (17 CPI),
Condensed elite pitch (20 CPI),
Normal proportional, Condensed proportional.

Double-height,

Double width,

Triple width,

Double-sized,

Quad-sized.

Various line and character spacings:

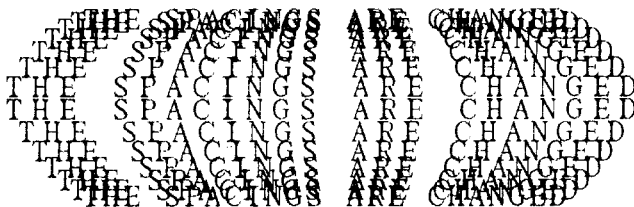

Other features:

OUTLINED, SHADOWED, OUTLINED WITH SHADOWED,
Emphasized, Double-strike, *Italics*,
Underlining, ~~Strike through~~, Overlining,
SUPERSCRIP^T and SUBSCRIP_T,

Download characters: *******TTTTT*******

Dot graphics:

M&W

MEMO

Chapter 2

SETTING UP THE PRINTER

This chapter describes the following procedures to set up your new printer.

If you have optional accessories, refer to Chapter 7 after setting up the printer.

- Printer placement
- Unpacking the carton box
- Mounting the platen knob
- Installing the ribbon cartridge
- Configure your software for the printer

PRINTER PLACEMENT

Before you start setting up your printer, make sure that you have a suitable place on which to locate it. By “a suitable place”, we mean:

- A firm, level surface which is fairly vibration-free
- Away from excessive heat (such as direct sunlight, heaters, etc)
- Away from excessive humidity
- Away from excessive dust
- A steady power supply that is not subject to power surges should be connected to the printer. For example, do not connect it to the same circuit as a large, noise-producing appliance such as a refrigerator or an air conditioner.
- Make sure the line voltage is the voltage specified on the printer’s identification plate.
- Install the printer where there is sufficient room for the fanfold paper stack and any paper being fed in or printed out.
- If you are connecting your printer with a parallel interface, make sure that the cable is within 2m (6ft) of the printer. An RS-232 connection using the optional SPC-8K interface converter can be made over longer distances.

UNPACKING AND INSPECTION

Now check each item in the box against Figure 2-1 to make sure that you have everything (there should be six items).

If any of these items are missing, contact your supplier.

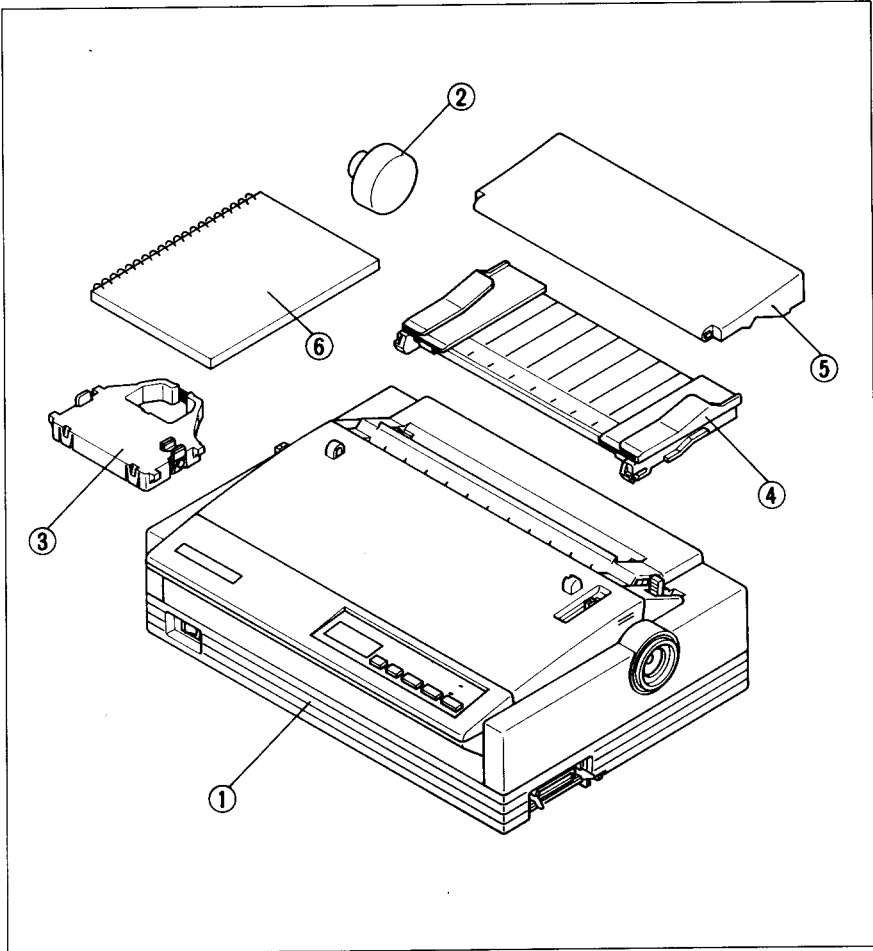

Figure 2-1. Check to make sure you have all six items: 1) Printer, 2) Platen knob, 3) Ribbon cartridge, 4) Paper guide, 5) Mute cover, and 6) User's manual.

The optional accessories which you may have ordered with your printer are:

- Film ribbon cartridge (FZ24)
- Font cartridges (FC series)
- RAM cartridge (RC-32Z, DC-32Z)
- Serial-Parallel converter (SPC-8K)
- Automatic sheet feeder (SF-10DS)
- Pull tractor unit (PT-10ZS)

For details of the optional accessories, refer to Chapter 7.

SETTING UP

Place the printer in the desired location, and remove all packing material from the printer as shown in Figure 2-2. This packing material is intended to prevent damage to the printer while in transit.

You will want to keep all the packing material, along with the printer carton, in case you have to move the printer to a new location.

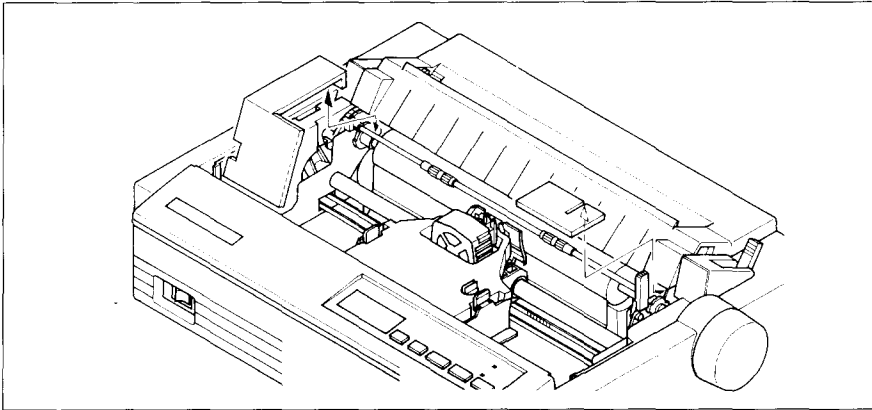

Figure 2-2. Remove the packing material from the printer.

Installing the platen knob

The platen knob is packed into an accessory box with other accessories.

Align the knob on the platen shaft, which is located on the right-hand side of the printer. Rotate the knob on the shaft before pushing the knob fully into position.

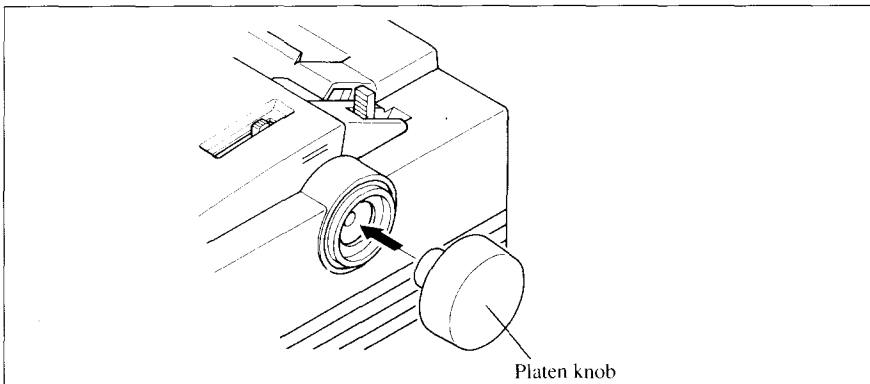

Figure 2-3. Installing the platen knob.

Removing the front cover

Open the front cover by lifting up the back cover using the two grips on either side, then remove the cover by pulling up (see Figure 2-4).

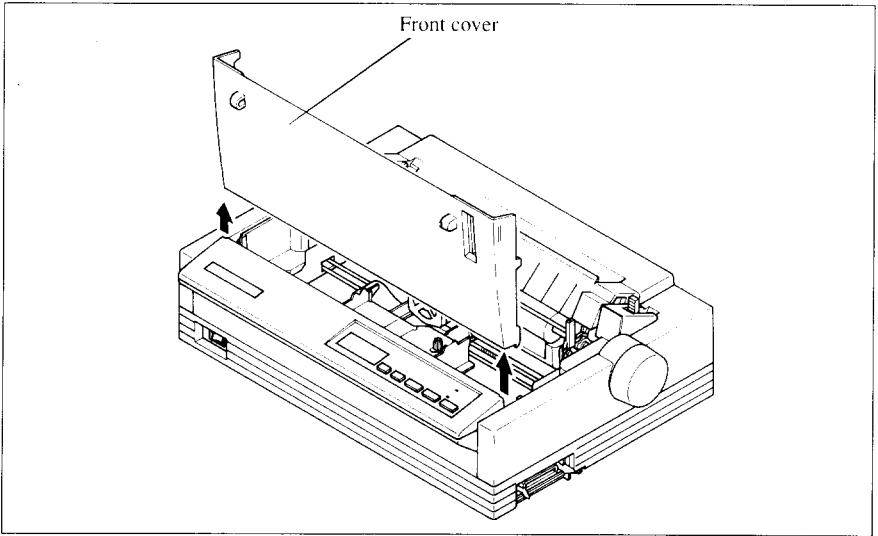

Figure 2-4. Open the front cover, and remove it by pulling up.

NOTE: You can keep the front cover installed on the printer, as shown in Figure 2-5. But, in this case you must take care not to injure your fingers with the tear assist edge.

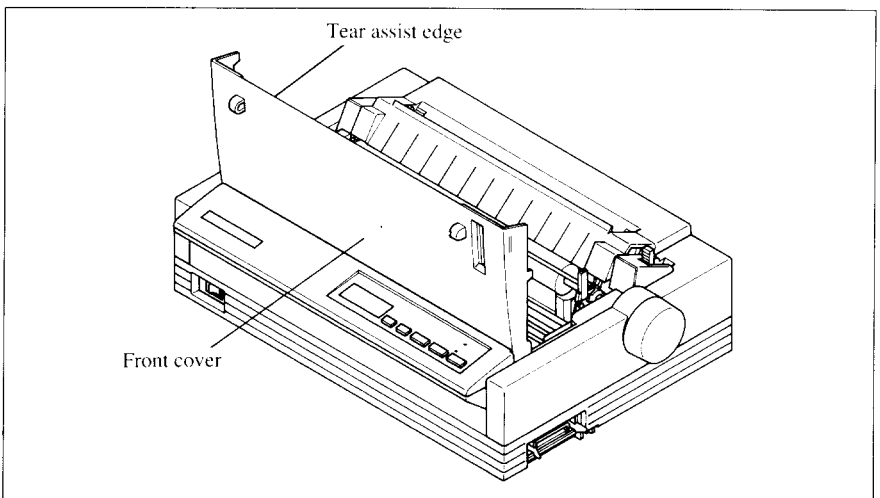

Figure 2-5. The front cover can stay on the printer.

Installing the ribbon cartridge

Now install the ribbon with the following procedure.

1. Take the slack out of the ribbon by turning the tension knob on the ribbon cartridge clockwise as shown by the arrow.

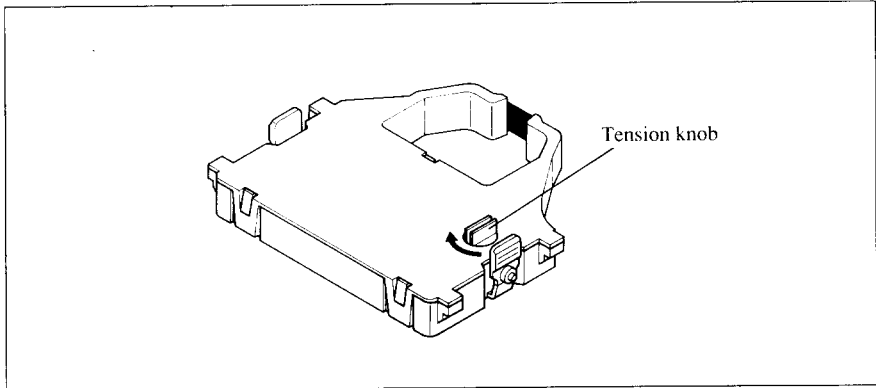

Figure 2-6. Take out the slack of the ribbon by turning the tension knob on the ribbon cartridge.

2. Guide the ribbon between the print head and the silver print head shield, making certain that the spindles on the cartridge holder fit into the sockets on the cartridge itself.

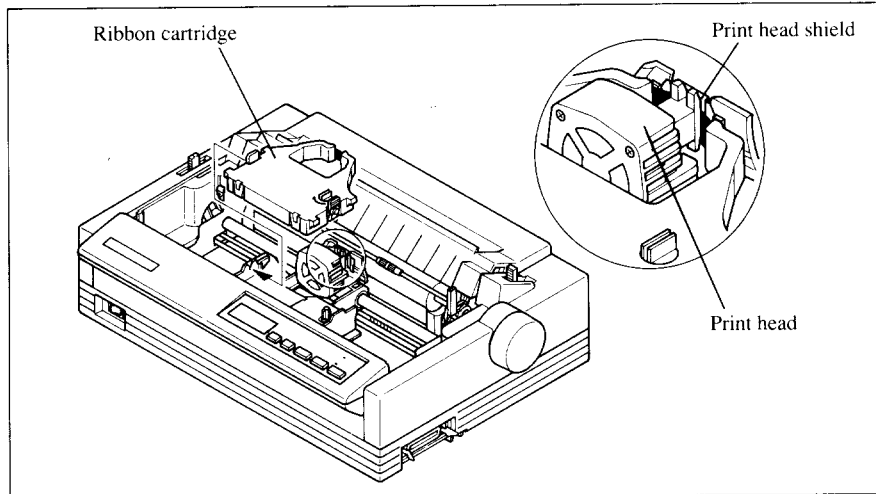

Figure 2-7. Installing the ribbon cartridge.

3. Make sure that the ribbon is positioned between the print head and the print head shield as shown in Figure 2-8.
4. Take the slack out of the ribbon again by turning the tension knob.

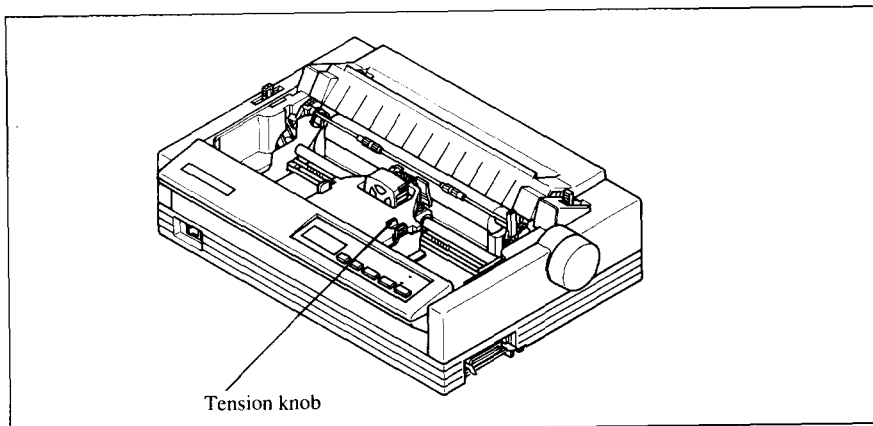

Figure 2-8. Make sure that the ribbon is positioned correctly.

Installing the front cover

After you have installed the ribbon cartridge, re-install the front cover.

1. Insert the tabs into the slots on the printer case.
2. Swing down the rear of the front cover to close it.

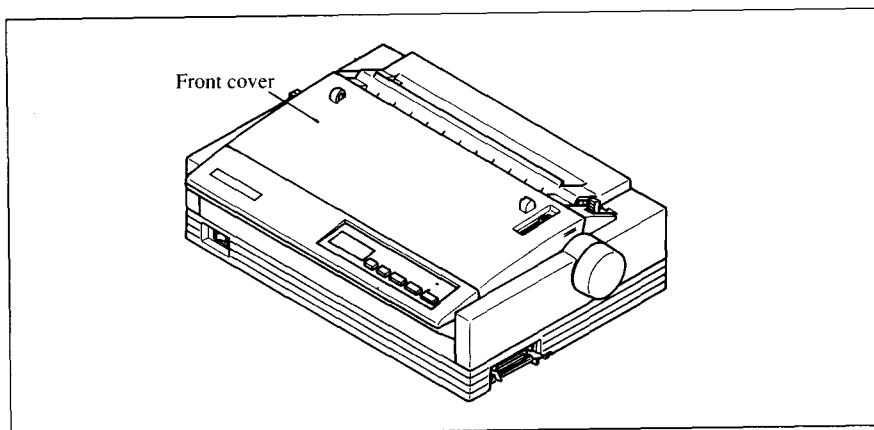

Figure 2-9. Installing the front cover.

Installing the paper guide

Follow the procedure below to install the paper guide:

1. Insert the two slots on either side of the paper guide into the two tabs on the rear cover.
2. Place the paper guide horizontally, as shown in Figure 2-10.

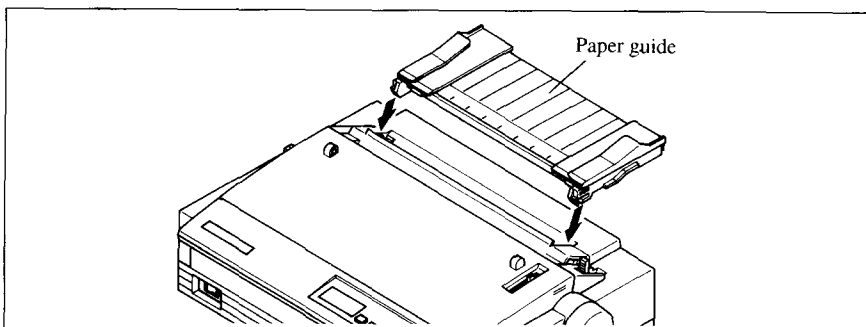

Figure 2-10. Installing the paper guide horizontally.

Installing the mute cover

Follow the procedure below to install the mute cover:

1. Insert the tab on the left side of the mute cover into the hole on the front cover.
2. Insert the other tab into the slot on the front cover.
3. Swing down backward to close the mute cover.

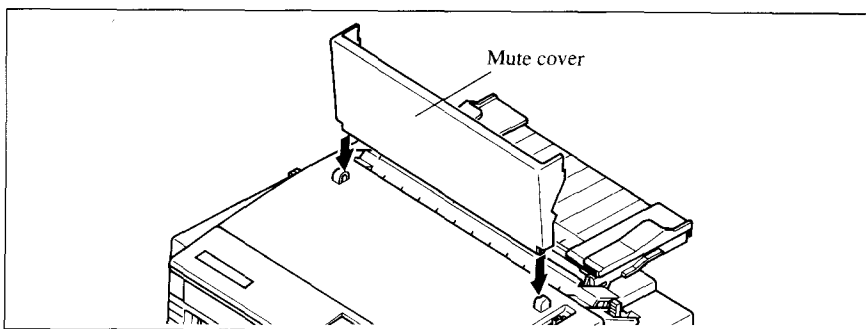

Figure 2-11. Install the tabs on the mute cover, then swing down to close it.

Leave the front and mute covers closed during normal operation. The cover keeps out dust and dirt and reduces the printer's operating sounds. Open the cover only to change the ribbon or make an adjustment.

Connecting the interface cable

Connect the printer to your computer using a standard Centronics parallel interface cable. On a PS/2 or PC/AT-type computer, this means that you use the 25-pin D-type connector at the computer end, and the Amphenol-type 36-pin connector at the printer end. The configuration of the printer's connector is given in Chapter 11 should you need a cable for connecting to another computer.

If you need to connect to a serial port, use the optional Serial-Parallel Converter, SPC-8K.

Follow the procedures below to connect the interface cable:

1. Turn off the power switch both the printer and the computer.
2. Connect the interface cable to the printer as shown in Figure 2-12. Make sure that you press the plug into the interface connector.

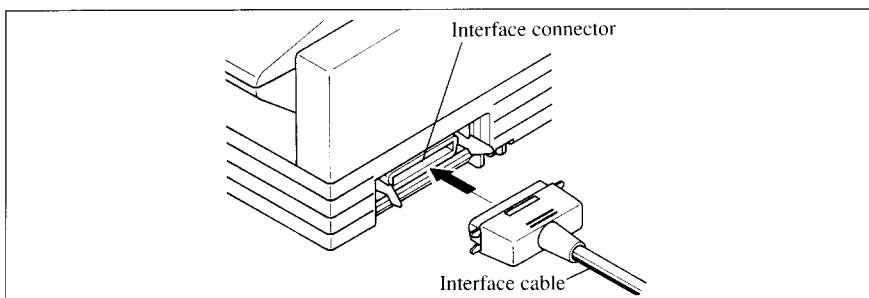

Figure 2-12. Connecting the interface cable.

3. Move both clips inside the extended prongs on the sides of the plug until you hear a click.

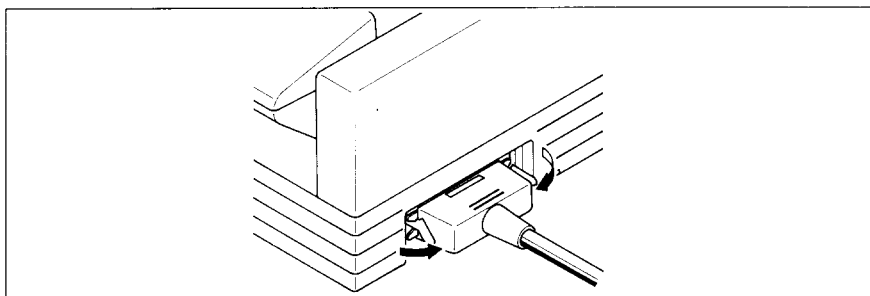

Figure 2-13. Move the clips until you hear a click.

4. Connect the other end of the interface cable to your computer. Use your computer instructions to attach the interface cable.

Configuring your software for the printer

Most application software programs let you specify the type of printer you are using so that the software can take full advantage of the printer's features. Many of these software packages provide an installation or setup program that presents a list of printers.

This printer is set up to emulate the Epson printer commands at the factory. If you want to emulate the IBM printer commands, you can select it with the Electronic DIP Switch (EDS) mode.

Choose one of the following (in order of preference) according to your selected Emulation mode.

#	Standard (Epson) mode	IBM mode
1	Star LC24-20	IBM PS/1 printer
2	Star LC24-200	Proprinter X24E
3	Epson LQ-860	Proprinter 24P
4	Epson LQ-850	
5	Star LC24-10	

You can also select one of NEC 24-wire printers to print graphics in the Standard emulation mode.

If your software package does not mention printers by name, but asks instead what features your printer is capable of, the most common questions are: "Can your printer perform a backspace?" and "Can it do a hardware form feed?". You should answer "Yes" to both these questions.

Make sure that the Electronic DIP Switch (EDS) is set for the correct printer emulation, and that you have also selected the appropriate character set. (Refer to Chapter 5 for detailed information on the EDS mode.)

If you are in doubt about the configuration of your application software, seek expert advice. Your software supplier will probably be your most qualified reference.

Chapter 3

PAPER INSTALLATION AND USE

This chapter describes instructions for printing such as selecting paper types, adjusting the printing gap, and installing paper.

SELECTION OF PAPER

Your printer accepts any of the following types of paper:

- Single sheets (cut forms) and stationary
Use the friction feed or the optional Automatic Sheet Feeder.
- Fanfold forms
Fanfold forms have holes along the sides and perforations between the sheets. They are also called sprocket forms, continuous forms, or just plain “computer paper”.
Printing on or near the perforations of continuous fanfold forms may reduce printing quality, misalign the fanfold forms, or cause a paper jam.
- Multi-part forms
You can use multi-part forms that have up to three parts including the original. It is recommended that you load multi-part forms using the bottom feed slot with the optional Pull Tractor Unit.
Use pressure sensitive multi-part forms with both side edges glued and a difference in thickness of 0.05mm or less between the side edges.
- Labels
When printing labels, always select the type mounted on a continuous backing sheet with sprocket holes for use with a tractor.
Do not try to print labels as cut forms because labels on a shiny backing sheet almost always slip a little.
It is recommended that you load labels from the bottom feed slot with the optional Pull Tractor Unit.

NOTES:

1. Never feed labels backward. Labels can easily peel off the backing and get stuck in the printer.
To remove labels from the paper path after you finish printing, first tear off the labels at a point before the paper slot.
2. Use labels only under normal operating conditions.
The labels are especially sensitive to temperature and humidity.
3. Do not leave labels loaded in the printer between jobs. They curl around the platen and may jam when you resume printing.

Figure 3-1 shows the recommended print area for each type of papers.

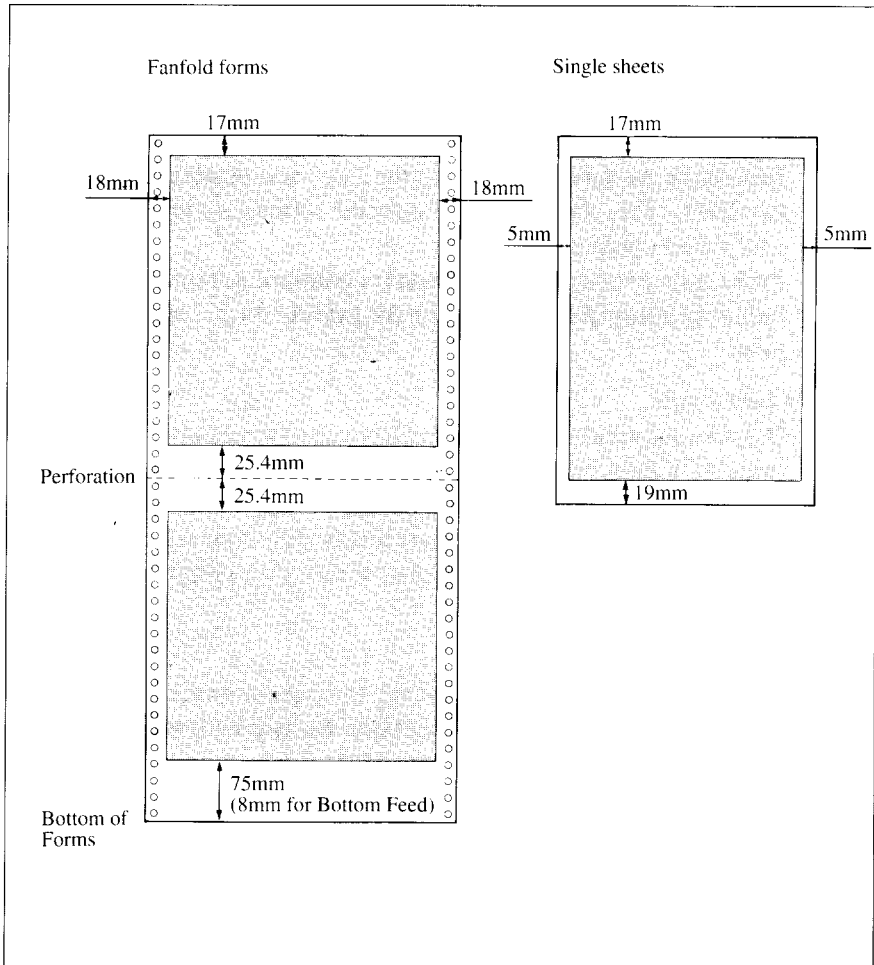

Figure 3-1. Recommended print area for acceptable papers.

ADJUSTING THE PRINTING GAP

The distance between the print head and the platen can be adjusted to accommodate different paper thicknesses. The adjustment lever is located at the left side of the printer. Pushing the adjustment lever towards the rear of the printer narrows the gap; pulling it towards the front of the printer widens the gap.

There are five positions, and you can feel the lever clicking into each position. The second position from the rear (marked with “•”) is the one most commonly used for single sheets of paper.

Try different positions until you get the best printing results.

NOTE: Printing with an inappropriate gap may drastically shorten the life of the print head.

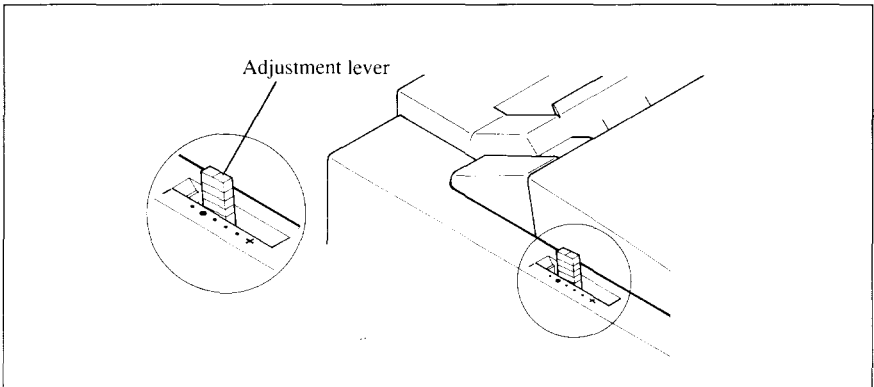

Figure 3-2. Location of the adjustment lever.

The following table provides the recommended lever positions for each paper types as a reference.

Paper Type	Weight (Each paper)	Thickness (mm) (Total)	Recommended Lever position
Single	52 ~ 90 g/m ² (14 ~ 24 lbs)	0.07 ~ 0.12	2nd or 3rd
2-ply	40 ~ 56 g/m ² (11 ~ 15 lbs)	0.11 ~ 0.15	2nd or 3rd
3-ply	40 ~ 56 g/m ² (11 ~ 15 lbs)	0.18 ~ 0.23	3rd or 4th

LOADING FANFOLD FORMS

This printer accepts fanfold forms up to 10" wide.

This printer can feed fanfold forms either from the rear or from the bottom of the printer, as shown in Figure 3-3.

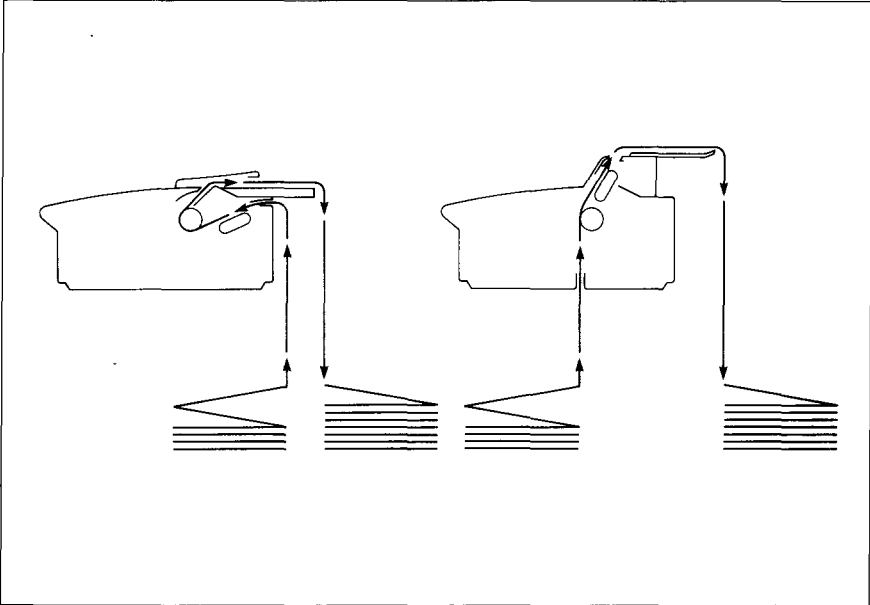



Figure 3-3. Paper path for fanfold forms.

This section will take you through the procedures for loading, parking and unparking fanfold forms from the rear of the printer.

If you want to feed paper from the bottom, you must use the optional Pull Tractor Unit. (Refer to Chapter 7.)

Loading the paper

1. Place a stack of fanfold paper behind and below the printer.
2. Turn the printer's power OFF.
3. Pull the release lever toward the front of the printer (). This has the effect of releasing the paper from the platen roller, and engaging the tractor feed.
4. Open the mute cover on the front cover, as shown in Figure 3-4.

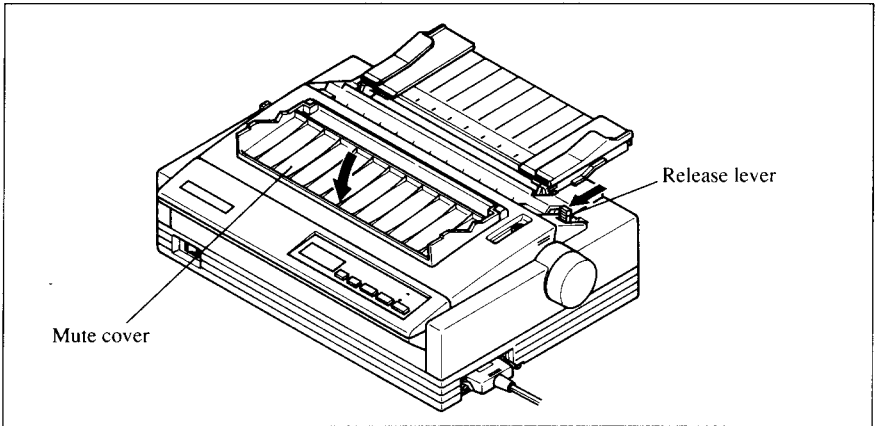

Figure 3-4. Opening the mute cover and correct lever position.

5. Open the rear cover using the two grips on either side, as in Figure 3-5.

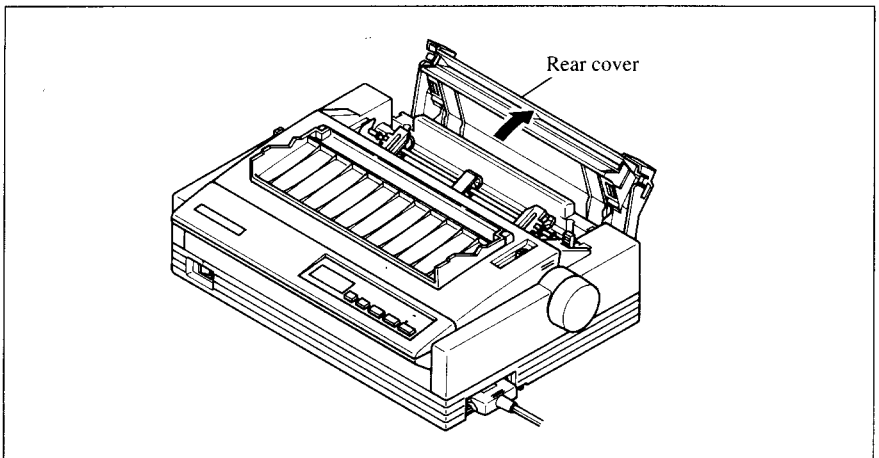

Figure 3-5. Opening the rear cover.

6. Pass the paper between the printer case and the rear cover.

- Open both tractor covers and mount the paper by aligning holes with the pins on the tractor unit.

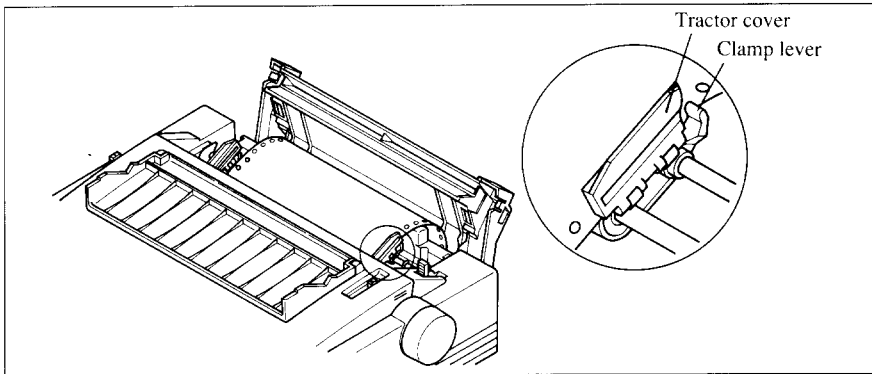

Figure 3-6. Mount the fanfold paper over the tractor units.

- Adjust the spacing of the tractor units by sliding them along the bar, using the clamp lever at the back of each unit to release and lock them in position. When the clamp lever is up, the unit is released, and when it is down, the unit is locked.
- Now close the tractor covers, again making sure that the paper holes are aligned with the pins on the tractor units. If they are not aligned properly, you will have problems with paper feeding, possibly resulting in tearing and jamming of the paper.

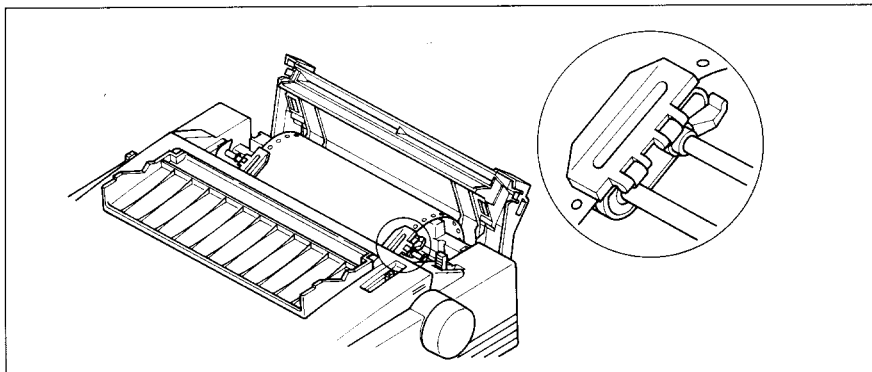

Figure 3-7. Adjust the tractor positions to accommodate the width of fanfold forms.

- Close the rear cover and the mute cover, then set the paper guide in the horizontal position, as shown in Figure 3-8. This will separate the printed from the unprinted paper.

11. Turn on the power using the switch located at the front of the printer. The printer will beep, indicating that the paper is not yet fully loaded. A “PE” message will also flash on the LCD display to confirm this.

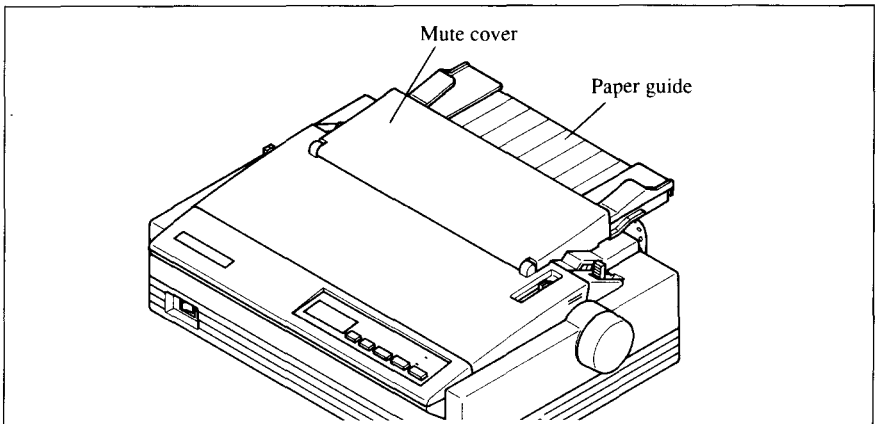

Figure 3-8. Close the rear cover and the mute cover, then set the paper guide horizontally.

12. Now pull the bail lever toward the front of the printer. The paper will be fed and adjusted past the print head to a position ready for printing.

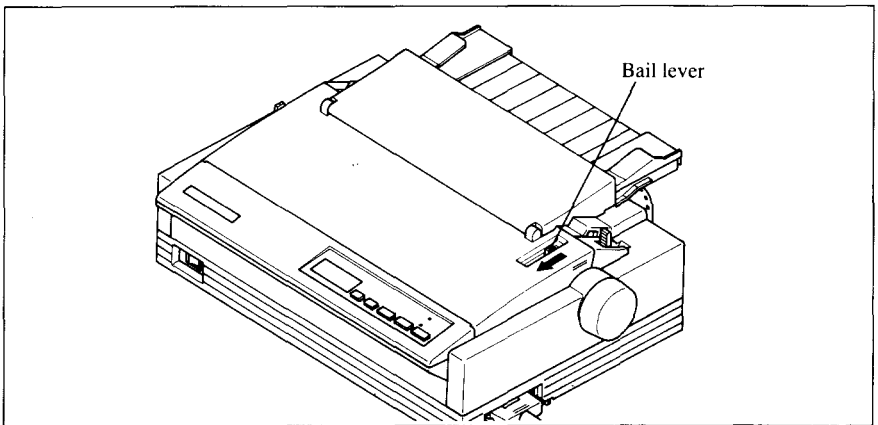



Figure 3-9. Pull the bail lever toward the front of the printer to load paper.

NOTE: Do not return the bail lever backward. The bail lever automatically returns to its original position after the paper goes through under the bail lever location.

13. If you want to set the paper to a different position, set the printer off-line by pressing the ON LINE button, then set the paper by using the micro-feed function. (For details, refer to Chapter 4.)

Paper parking

After loading fanfold paper with internal tractor unit, you do not have to unload it when you want to print on a cut sheet. The printer will “park” it for you if you follow the procedure below.

1. To begin paper parking, start with the power ON, fanfold paper loaded in printing position, and the release lever toward the front of the printer ().
2. Press the **ON LINE** button on the control panel to set the printer off-line. The ON LINE indicator light will turn off.
3. Tear off the printed form at the last perforation, leaving not more than about half a page showing above the front cover. If necessary, press the **PAPER FEED** button to feed paper forward until a perforation is located just above the front cover, and tear there.

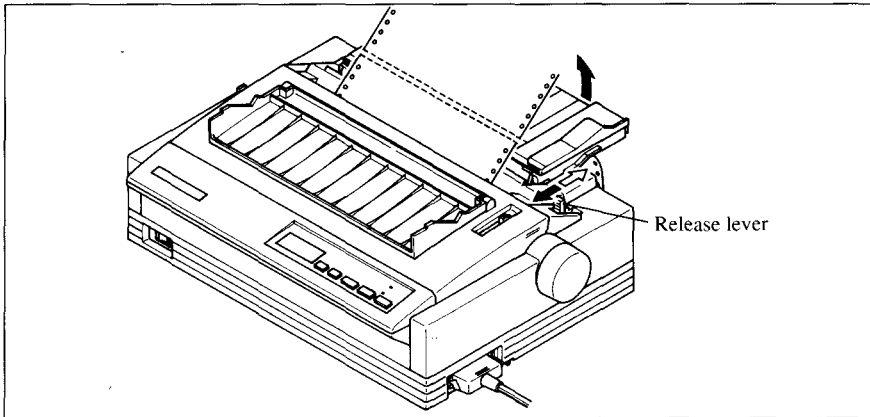



Figure 3-10. Tear off the printed fanfold paper.

4. Press the **EJECT/PARK** button on the control panel.
The printer will automatically feed the fanfold form backward until the paper is completely free of the platen.
5. A “PE” message will now appear on the LCD display and a beep will sound.
6. Move the release lever toward the rear of the printer ().
7. Mount the paper guide in the upright position.

Now you can load single sheets. The fanfold paper remains parked at the back of the printer.

NOTE: You cannot park the fanfold paper if you have loaded it using the optional Pull Tractor Unit.

Paper unparking

When you want to resume using fanfold paper, the procedure is as follows.

1. Remove all cut forms from the printer.
2. Mount the paper guide in the horizontal position.
3. Move the release lever toward the front of the printer ().
4. Move the bail lever forward. The printer will automatically feed the parked fanfold paper back into position for printing.

NOTE: The printer beeps intermittently if you move the release lever while the paper is loaded.

Tear off function

At the end of printing, use this tear off function to cut off the printed form without advancing blank forms.

1. Open the mute cover on the front cover.
2. Pull the bail lever forward.
The paper will be fed to the tear off position and the bail lever will automatically close.
3. Tear off the printed form with the tear assist edge of the front cover.
4. Pull the bail lever forward.
The paper automatically returns to the printing position.

NOTE: Do not return bail the lever after return to the on-line state.

LOADING SINGLE SHEETS

This section will take you through the procedures for loading single sheets of paper.

The paper path for cut forms is shown in Figure 3-11.

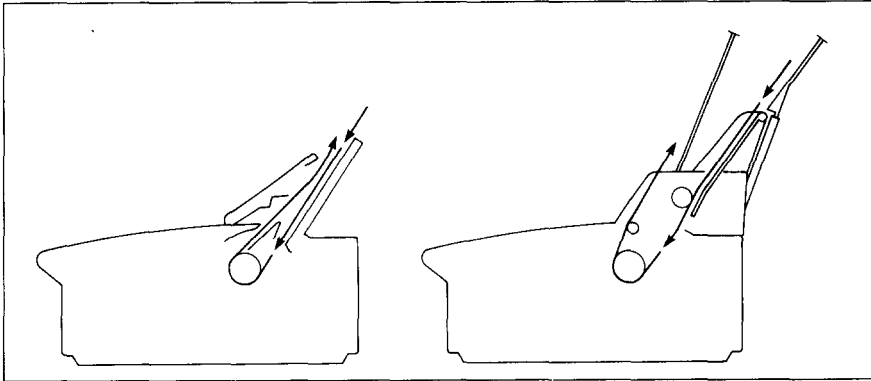

Figure 3-11. Paper path for cut forms.

If you are using the optional Automatic Sheet Feeder, refer to Chapter 7.

1. Raise the paper guide in position on the rear cover of the printer.

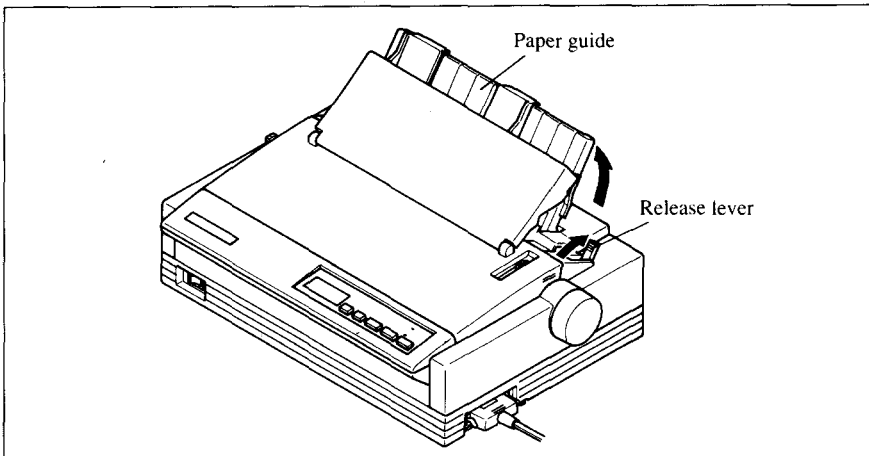



Figure 3-12. Raise the paper guide for single sheets.

2. Adjust the paper guides to match the size of the paper you will be using. Remember that printing will start some distance from the left-hand edge of the carriage.

3. Turn on the power using the switch located at the front of the printer. The printer will beep, indicating that there is no paper in position for printing. The “PE” message will also flash on the LCD display to confirm this.
4. Make sure that the release lever is at rear position (). If fanfold paper is already mounted in the printer, press the **EJECT/PARK** button to park the paper in the off-line state, then move the release lever toward the rear of the printer.
5. Place a single sheet between the guides, placing the side on which you want to print towards the back of the printer. Gently push the paper down in the guides until you feel it stop.

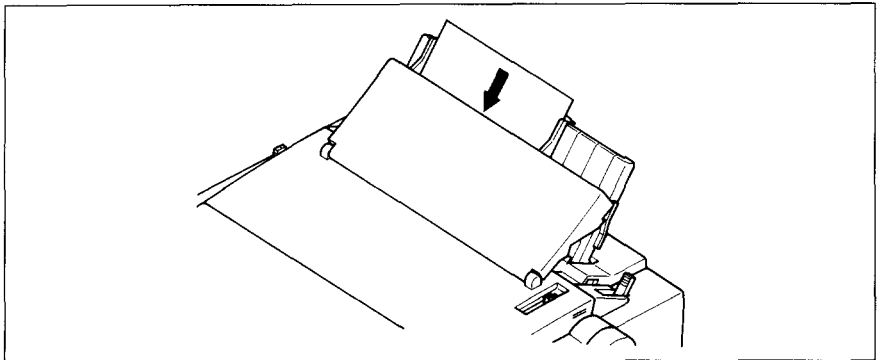

Figure 3-13. Place a single sheet between the guides.

6. Now pull the bail lever toward the front of the printer. The paper will be fed into the printer and adjusted past the print head to a position ready for printing.

NOTE: Do not place the bail lever in the backward position. The bail lever automatically returns to its original position after the paper goes through under the bail lever location.

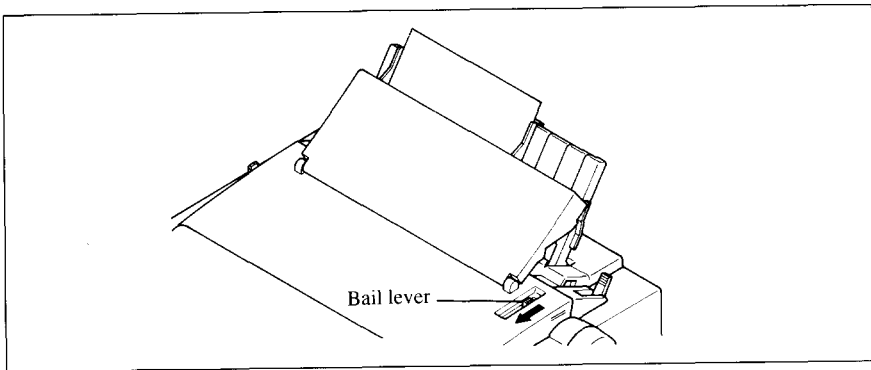

Figure 3-14. Pull the bail lever forward to load paper.

7. If you want to set the paper to a different position, set the printer off-line by pressing the ON LINE button, then set the paper position by using the micro-feed function. (For details, refer to Chapter 4.)

Chapter 4

CONTROL PANEL OPERATIONS

The control panel buttons can be pressed individually to perform the operations indicated by their names. Other functions can be achieved by holding these buttons down when you turn the printer's power on, or by pressing the control panel buttons in combination.

This chapter explains all the button and indicator functions.

- Pause printing
- Feed paper (fast and slow, forward and reverse)
- Park fanfold forms
- Set the top-of-form position
- Select the print pitch
- Select a font
- Print test patterns
- Prevent software from changing the panel pitch and font selections
- Adjusting the print alignment for bi-directional printing
- Print a hexadecimal dump
- Clear the printer's buffer
- Save macro definition

BUTTON AND INDICATOR FUNCTION

The printer is equipped with five buttons on the control panel. From left to right they are **FONT**, **PITCH**, **EJECT/PARK**, **PAPER FEED** and **ON LINE**.

The following is a brief guide to the buttons and indicators on the control panel.

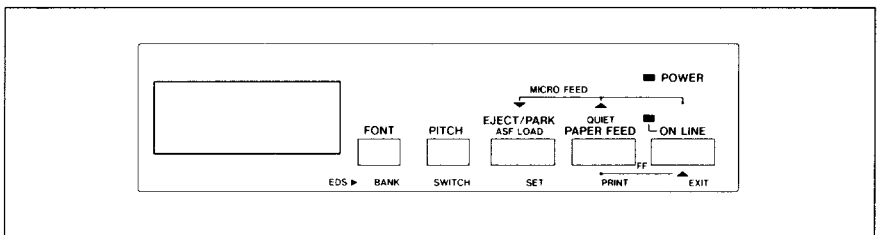

Figure 4-1. Control panel.

ON LINE

The ON LINE button sets the printer on-line and off-line. The status changes each time you press the button.

When the printer is on-line, it can receive and print data from the computer and will be indicated by the ON LINE indicator being lit. When the printer is off-line, it stops printing and sends the computer a signal indicating that it cannot accept data.

The printer powers up in the on-line status when paper is loaded. If paper is not loaded, the printer powers up off-line with the "PE" message and the Power indicator light will blink. When you load paper, the printer goes on-line.

You will want to press the ON LINE button:

- Before and after any other panel operation

The other panel buttons operate only in the off-line state. Press the ON LINE button to go off-line. After performing the panel operation(s), press the ON LINE button again to go back on-line.

- To pause during printing

If you press the ON LINE button during printing, the printer stops printing and goes off-line, allowing you to check the printout or change a control panel setting. Printing resumes when you press the ON LINE button again to go back on-line.

PAPER FEED

If you press and release this button while off-line, the paper will feed forward one line. If you hold the button down, the printer will perform consecutive line feeds.

If you also press the ON LINE button while you are line-feeding, the paper will feed automatically to the top of the next page. This is explained later.

If you press the PAPER FEED button while on-line, this will alternately flash the "QUIET" message on the display. When in Quiet mode with the "QUIET" message, the printer will print slightly slower, but at a reduced noise level.

EJECT/PARK

NOTE: This button has no effect if the bottom feed mode is selected.

This button results in different functions depending on the position of the release lever.

If the release lever is facing toward the rear of the printer for the cut forms (), pressing this button ejects the paper.

If the release lever is facing toward the front of the printer for the fanfold forms (), pressing this button parks the forms.

PITCH

This button allows you to select the printing pitch. Remember that the printer must be off-line for you to do this. Successive presses of this button will display (and select) the following options in order (Note that the super-condensed pitch is not available with Standard/Epson mode, and condensed proportional pitch is not available with IBM mode):

Pitch	LCD Message
Pica (10 CPI)	10
Elite (12 CPI)	12
Semi-condensed (15 CPI)	15
Condensed pica (17 CPI)	17
Condensed elite (20 CPI)	20
Super-condensed (24 CPI)	24
Proportional	P5
Condensed proportional	Pc

FONT

This button selects the font to be printed. Draft font is selected at power-up unless the default settings are changed. To change the font, set the printer off-line, then press the **FONT** button repeatedly until the proper font is highlighted on the LCD display. The selections cycle in the following order:

Font	LCD Message
Roman	ROMAN
Sanserif	SANSERIF
Courier	COURIER
Prestige	PRESTIGE
Script	SCRIPT
High-Speed Draft	HS-DRAFT
Draft	DRAFT
Optional font	OPTION

NOTE: If the optional Font Cartridge is not installed, the “OPTION” message will not illuminate.

POWER-UP FUNCTIONS

In addition to their normal functions, all of the control panel buttons perform “special” functions if you hold them down while switching the power button on.

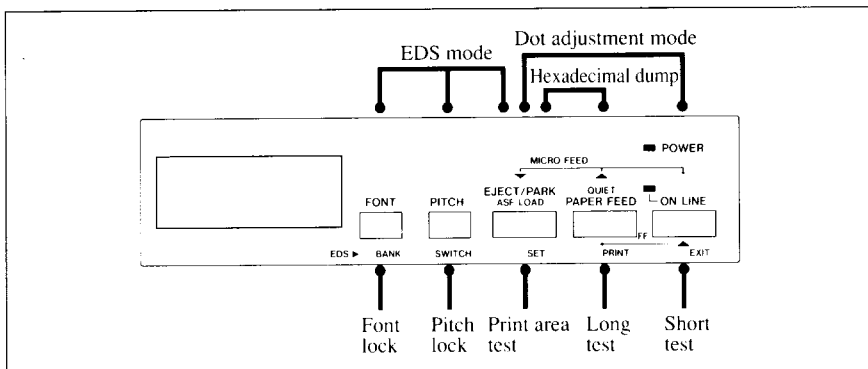

Figure 4-2. Power-up functions of control panel.

Short test mode

If the printer is turned on while the **ON LINE** button is pressed, the printer will enter the short self-test mode, with the “P1” message on the LCD display. The printer will print the version number of the printer’s ROM, followed by seven lines of the character set.

Each line will be offset by one character from the one before it. The final result will be something like Figure 4-3.

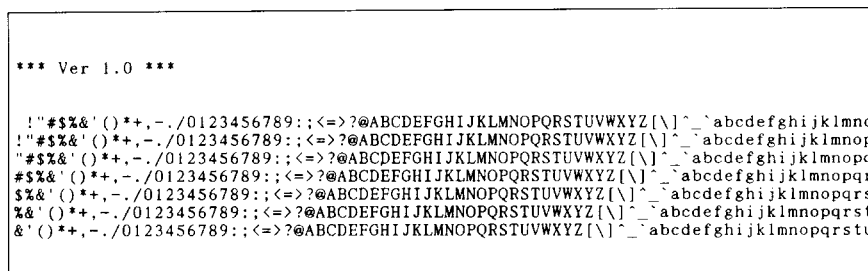

Figure 4-3. Short self-test.

Since the self-test prints across the full width of the carriage, it is recommended that the printer is loaded with the widest paper possible to avoid damage to the print head and/or platen.

Print area test mode

By holding the **EJECT/PARK** button down during power-up, the printer will enter the print area test mode. You can find how many lines on your paper are available for printing with 1/6-inch line feeding. The printer will show the “P3” message on the LCD display and print the first line message on the paper, then print the last line message after feeding to the bottom of the page.

If you have loaded the fanfold paper, only the first line message is printed.

Pitch lock mode

By holding the **PITCH** button down during power-up, the print pitch can only be selected from the control panel. This prevents software interference. You will hear an acknowledging beep, and the printer will show the “P-LOCK” message on the LCD display as power comes on.

After the beep tone, you can set the printer off-line, select a print pitch, then return to on-line and start printing. The pitch you selected will show on the LCD display and will not be reset or otherwise changed by any commands your software may issue.

Font lock mode

By holding the **FONT** button during power-up, fonts can only be selected from the control panel. This prevents software interference. There will be an acknowledging beep and “F-LOCK” message on the LCD display. After which you can set the printer off-line, select a font, then return to the on-line state and begin printing. The selected font will not be changed by any commands your software may issue.

Font and Pitch lock mode

If you want to protect both the font and pitch settings from software changes, press both the **FONT** and **PITCH** buttons during power-up. There will be two acknowledging beep tones with “P-LOCK” and “F-LOCK” messages on the LCD display.

Pressing these buttons during power-up does not prevent you from making any number of changes later from the control panel.

- To change the mode for which the bi-directional adjustment is performed, press the button. This will cycle between "LQ", "DRAFT", "DRAFT COND" and "BIT IMAGE".
Repeat the process for all print modes.

```

*** DOT ADJUSTMENT SETTING ***

LQ          0 : |||...|||
LQ          -1 : /.../
LQ          0 : |||...|||
 → DRAFT      0 : |||...|||
 → DRAFT      +1 : \...\  

 → DRAFT      0 : |||...|||

```

- To exit from this mode, press the button.

```

*** DOT ADJUSTMENT SETTING ***

LQ          0 : |||...|||
LQ          -1 : /.../
LQ          0 : |||...|||
DRAFT       0 : |||...|||
DRAFT       +1 : \...\  

 → DRAFT       0 : |||...|||
 → DRAFT COND  0 : |||...|||
 → BIT IMAGE  0 : |||...|||
*** END ***

```

Hexadecimal dump

This feature is useful for programmers who are debugging printing programs and want to see the actual codes the printer is receiving. (Some computers change the codes the programmer intended.)

In this mode, all data received will be printed in a hexadecimal dump format, rather than the control codes being acted on as command codes.

This mode is accessed with the following procedure:

1. While holding both the PAPER FEED and EJECT/PARK buttons down, turn power ON. A beep tone will be heard and the “Hd” message on the display.
2. Begin printing. In place of the usual printout you will get a formatted dump showing exactly what data the printer receives. Each line presents sixteen characters, their hexadecimal codes to the left and printable characters printed on the right.
3. At the end of the hexadecimal dump, set the printer off-line with the ON LINE button. This is necessary to print the last line.

SWITCH COMBINATION FUNCTIONS

Several additional functions can be achieved by pressing the control panel buttons in combinations.

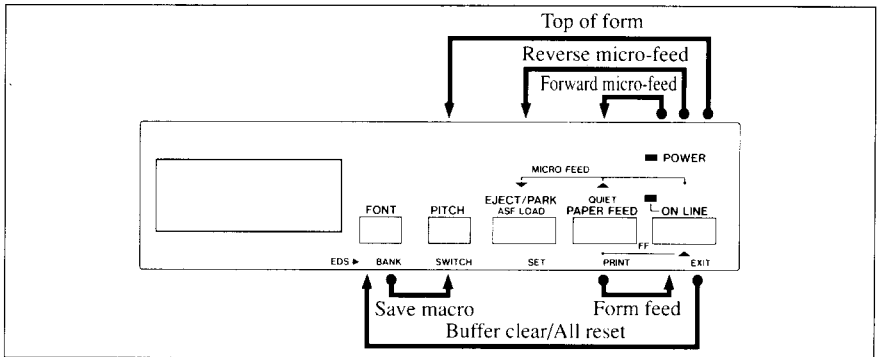

Figure 4-5. Switch combination functions of control panel.

Form feed

If you are using cut forms, this operation ejects the current page. If you are using fanfold forms, it feeds to the top of the next page.

1. Press the button to set the printer off-line.
2. Press the button and hold it down. The printer will start performing successive line feeds.
3. While holding the button down, press the button, then release both buttons at the same time. The printer will smoothly eject the current page.

Top of form

When you power on the printer, the top-of-form position is automatically set to the current position. If this is not where you want the top of the page to be, you can change the top-of-form position as follows:

1. Press the button to set the printer off-line.
2. Move the paper to the desired top-of-form position by pressing the button, or by performing a forward or reverse micro-feed.
3. Press and hold the button.
4. While holding the button down, press the button, then release both buttons at the same time. The "--" message will show on the LCD display, that the top-of-form position has been set.

Forward micro-feed

For fine alignment, you can feed the paper forward in very small increments as follows:

1. Press the button to set the printer off-line.
2. Press the button again and hold it down.
3. While holding the button down, press the button. The paper will start advancing in a series of small steps.
When you want to stop, release both buttons.

Reverse micro-feed

You can also feed the paper in small increments in reverse, to return to a higher position on the same page.

1. Press the button to set the printer off-line.
2. Press the button again and hold it down.
3. While holding the button down, press the button. The paper will start moving backwards in a series of small steps.
When you want to stop, release both buttons.

NOTE: Open the bail lever when the printer beeps intermittently and the “Er” message shows on the LCD display near the edge of the paper.

Changing the auto loading position

Normally, the printer automatically loads the paper one line from the top edge. If you want to change this value, follow this procedure:

1. Load the paper by moving bail lever toward the front of the printer.
2. Change the print position using the micro feed function.
The value on the LCD display shows the micro-feed value from the default position.
3. After you get the desired position, press the button to save the value.

This position will remain unless you power off the printer. If you want to retain this position even after you turn off the power, store it using the Macro Definition function, which is described later.

Note that you can only change this value immediately after loading paper. If you feed paper, you cannot change the auto loading value.

Clearing the buffer/All reset

The printer stores received data in a large memory buffer. This creates a problem when you want to abandon a printing job and restart: the printer may be holding more data in its buffer than it has actually printed, and this unprinted data must be cleared out before restarting. Turning power off is one way to clear the buffer, but there is another way:

1. Halt the printing program on the computer. If printing stops immediately, the buffer is clear and the rest of this procedure is unnecessary. If printing does not stop, continue as follows:
2. Press the button to set the printer off-line. Printing will now stop, but there may be data remaining in the buffer.
3. Press and hold the button.
4. While pressing the button down, press and hold the button. Continue holding these two buttons down, you will hear a beep tone and the "bC" message appears on the LCD display. If you hold these buttons down longer, you will hear three beep tones and the printer has been initialized to the power-on default settings.
5. Release these buttons, make any necessary control panel settings, then set the printer back on-line.

It is essential to stop the printing program on the computer before you go off-line. Otherwise, when you go back on-line the computer will start sending data again and the printer will continue printing, with missing data from when the buffer was cleared.

Save Macro Definition

You can save the current settings to the printer for later use with the following procedure:

1. Press the button to set the printer off-line.
2. Press the button and hold it down.
3. While holding the button down, press the button and hold them down until the "MACRO" message appears on the LCD display.
4. Release both buttons at the same time after this message appears on the LCD display to save the current setting.
If you release these buttons after the "MACRO" message has gone out on the display, the macro has been cleared.

NOTE: You can store the following settings with this procedure.

- Current Font
- Current pitch
- Current auto-loading amount for cut forms
- Current auto-loading amount for fanfold forms
- Current auto-loading amount in ASF mode

Data to be stored are controlled in Standard mode and IBM mode separately. For example, the data stored in the Standard mode are not effective in the IBM mode, and vice versa.

CONDITIONS INDICATED BY MESSAGES AND TONES

This section helps you identify the messages and the meanings of the tones.

Summary of display messages

Following table shows the summary of the messages on the LCD display.

LCD Message	Meanings and action
ROMAN	ROMAN LQ font is selected.
SANSERIF	SANSERIF LQ font is selected.
COURIER	COURIER LQ font is selected.
PRESTIGE	PRESTIGE LQ font is selected.
SCRIPT	SCRIPT LQ font is selected.
HS-DRAFT	High-Speed Draft font is selected. You cannot select print pitch except 10 CPI.
DRAFT	Draft font is selected. You cannot select proportional pitch with the Standard/ Epson mode.
OPTION	Optional LQ font is selected.
PITCH	Indicates the message below shows the current pitch.
EDS	EDS mode is currently selected and the message on the right indicates the current Bank and Switch number. Press the ON LINE button to exit the EDS mode.
F-LOCK	Font lock mode is selected. The printer ignores the font selection commands and prints with the font displayed on the panel. Turn off the power switch to cancel the font lock mode.
P-LOCK	Pitch lock mode is selected. The printer ignores the pitch selection commands and prints with the pitch displayed on the panel. Turn off the power switch to cancel the pitch lock mode.

LCD Message	Meanings and action
ON OFF	Displays in the EDS mode. Indicates the current status of the displayed EDS bank and switch number. Press the EJECT/PARK button to change the status.
QUIET	Quiet mode is selected. Press the PAPER FEED button while in the on line mode to return to the Normal mode.
MACRO	Front panel setting are saved in the printer's memory as a "MACRO".
P1	Short print test mode is selected.
P2	Long print test mode is selected. Turn off the power switch to cancel the long print test mode.
P3	Print area test mode is selected.
Hd	Hexadecimal dump mode is selected. Turn off the power switch to cancel the hexadecimal dump mode.
--	Top of form is set manually with the control panel.
bC	Buffer is cleared manually with the control panel.
PE	Paper is not loaded to the printer.
dR	Dot Adjustment mode is selected.
Er	Bail lever is closed before the paper goes through the location of the bail lever. Open the bail lever. Release lever is moved while the paper is in printing position.
EE	The memory of EDS settings is accessed.
E1	Print head error. Turn off the printer and turn it on again.
E2	Carriage home position error. Turn off the printer and turn it on again.
E3	Paper handling error. Turn off the printer and turn it on again.
E4	S.W.I. error. Turn off the printer and turn it on again.
E5	RAM check error. Turn off the printer and turn it on again.
E7	Watch dog error. Turn off the printer and turn it on again.

Summary of beep tones

Following table shows the summary of beep tones.

Beep tones	Meanings
Two seconds tone	Printer detects an error condition. Turn off the power switch and turn it on again.
Long tone, once	Printer detects an error condition. Turn off the power switch and turn it on again.
Four short tone sequence, two times	Printer is out of paper.
Short tone, once	<ul style="list-style-type: none">• Buffer is cleared.• Top of form is set.• Quiet mode is selected.• Tear off function is selected.• EDS mode is selected.
Short tone, twice	<ul style="list-style-type: none">• Macro definition is selected.• Quiet mode is cancelled.
Short tone, triple	<ul style="list-style-type: none">• Macro definition is cancelled.• Printer is reset.
One-quarter tone	<ul style="list-style-type: none">• Hexadecimal mode is selected.• Pitch lock mode is selected.• Font lock mode is selected.
One-quarter tone, twice	Pitch and Font lock mode is selected at a time.
Intermittent tone One-quarter tone, twice	<ul style="list-style-type: none">• Release lever is moved while the paper is in printing position.• Bail lever is closed before the paper goes through the location of the bail lever.

MEMO

Chapter 5

DEFAULT SETTINGS-EDS MODE

From the control panel you can change the parameters that define how your printer works. These parameters become your power-on settings. This function is called the Electronic DIP Switch (EDS) mode.

HOW TO SET THE EDS MODE

The EDS mode in this printer has 16 functions that you can set as the power-on default.

Turn the printer on while simultaneously holding the **FONT**, **PITCH**, and **EJECT/PARK** buttons.

The “EDS” message will show on the LCD display. This indicates that you have entered the EDS mode.

In EDS mode, the buttons on the control panel are used as shown below in Figure 5-1.

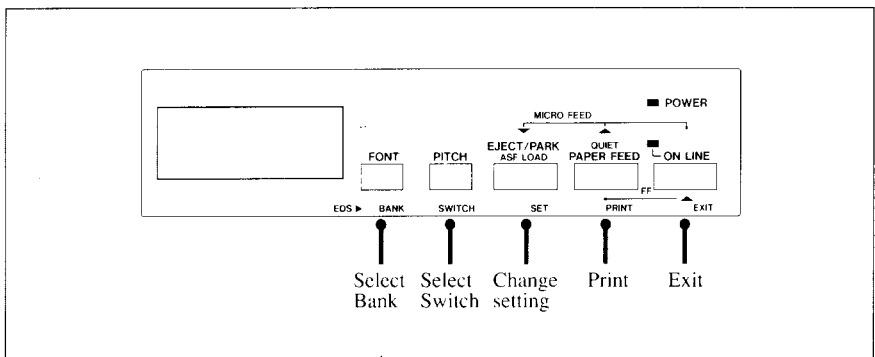

Figure 5-1. Button functions in the EDS mode.

- Use the **FONT** button to select the Bank Letter.
- Use the **PITCH** button to select the Switch Number.
- The LCD display on the control panel shows the current setting, ON or OFF.

Use the **EJECT/PARK** button to change the settings.

- Press the **PAPER FEED** button to print the current settings.
- Press the **ON LINE** button to save and exit the EDS mode.

FUNCTIONS OF THE EDS SETTINGS

The printer stores the parameters that you can select from the control panel while in the EDS mode.

A default is the setting that the printer will use if none is specifically selected by a program. When you first turn on or later reset your printer these default settings will take effect. By changing the settings, you can alter various printer functions to match your specific requirements. The following will help you choose the proper settings.

Bank-Switch	Function	ON	OFF
A-1	Emulation	STANDARD/EPSON	IBM
A-2	AEC Mode	Enabled	Disabled
A-3	RAM Usage	Input Buffer	Download Buffer
A-4	Auto LF with CR	Disabled	Enabled
A-5	Auto Sheet Feeder	Not installed	Installed
A-6	Graphics Direction	Bi-directional	Uni-directional
B-1	(Not used)		
B-2	Paper-out	Enabled	Disabled
B-3	(Not used)		
B-4	(Reserved)	Leave ON	
B-5	Printable Area	Type A	Type B
B-6	(Not used)		
C-1	Print Mode	(See below)	
C-2			
C-3	Page Length	(See below)	
C-4			
C-5			
D-1	Character Table (Standard mode) (IBM mode)	Graphics Set #2	Italics Set #1
D-2	IBM Code page or International Character Set	(See below)	
D-3			
D-4			
D-5	CR Centering	Disabled	Enabled
E-1	LQ Font Selection	(See below)	
E-2			
E-3			
E-4			
E-5			
F-1	EDS Setting	Current	Reset

NOTE: The factory default is the “ON” position for all functions except A-6 which is set to the “OFF” position.

Switch A-1: Emulation

Select the mode compatible with your computer and software. In the Standard/Epson mode, the printer operates like the Epson LQ-860/850. In the IBM mode, it operates like the IBM Proprinter X24E/24P, PS/1.

The ON position selects Standard/Epson mode. The OFF position selects IBM mode.

Switch A-2: Auto Emulation Change (AEC) Mode

This switch selects the Auto Emulation Change (AEC) mode.

When the AEC mode is enabled, the printer automatically judges the Emulation which your application program uses.

Switch A-3: RAM Usage

In order to download characters this switch must be in the OFF position. The printer then uses its RAM memory for storing character patterns and provides only a one-line print buffer. If you leave this switch ON, the printer uses its RAM memory as an input buffer, allowing the computer to send data faster than the printer prints.

Switch A-4: Auto LF with CR

If you leave this switch at the ON position, a separate line-feed code is required from your computer to obtain a line feed. If you move this switch to the OFF position, the printer performs both a carriage return and line feed each time it receives a carriage-return code.

Most computer systems send a line feed code, or both a carriage return and line feed, at the end of each line, so this switch should be left ON. If you get double line spacing when you expect single spacing, or if lines overprint each other, try changing the setting of this switch.

Switch A-5: Auto Sheet Feeder

In order to use the optional automatic sheet feeder (SF-10DS), move this switch to the OFF position.

Otherwise leave it ON.

Switch A-6: Graphics Direction

When printing in graphics mode, the printer may either print bi-directionally (in alternate directions) for speed or in one direction only (uni-directional for increased accuracy). For practically all purposes, however, bi-directional printing is sufficiently accurate.

Switch B-2: Paper-out

When this switch is OFF the printer ignores the paper-out detector and prints down to (and beyond) the bottom edge.

Switch B-4: This switch is used for technical purpose only. Leave this switch ON.

Switch B-5: Printable area

This printer can use two types of printing area format for single sheets (cut forms).

By putting the switch ON (“Type A”), the top of the first line of printing will start 1/6 inch from the top of the paper, and the printed area will end 1/6 inch from the bottom of the paper.

By putting the switch OFF (“Type B”), the first line of printing will start at one inch from the top of the paper, and the printed area will end to print 6 mm from the bottom of the printer.

Switches C-1 and C-2: Print Mode

These switches select the default print pitch and the fonts as shown below.

Print Mode	C-1	C-2
10CPI DRAFT	ON	ON
10CPI HS DRAFT	ON	OFF
17CPI DRAFT	OFF	ON
10CPI LQ	OFF	OFF

NOTE: If you change these switches after you have saved a macro, these new settings will override the macro setting.

Switches C-3 to C-5: Page Length

Leave these switches ON if you will be using 11-inch forms. You will need to change the switches if you will be using a different page length as shown below:

Page Length	C-3	C-4	C-5
11 inches/Letter	ON	ON	ON
8 inches	OFF	ON	ON
11.7 inches/A4	ON	OFF	ON
12 inches	OFF	OFF	ON
8.5 inches/Letter	ON	ON	OFF
14 inches/Legal	OFF	ON	OFF
10.5 inches/Executive	ON	OFF	OFF
7.25 inches/Executive	OFF	OFF	OFF

Switch D-1: Character Table

The action of this switch depends on the mode chosen with switch A-1.

Move this switch OFF to select Italic character table with the Standard/Epson emulation mode. If you leave this switch to the ON position, in place of italics you will get the graphic characters, international characters, and mathematical symbols of IBM character set #2.

In the IBM emulation mode, ON selects character set #2, which has international characters and fewer control words.

OFF selects character set #1, for computers with a 7-bit interface.

Switches D-2 to D-4: IBM Code Page or International Character Set

Except in the Standard Italic character set, these switches select the default character code page as shown below:

IBM Code Page	D-2	D-3	D-4	IBM Code Page	D-2	D-3	D-4
#437 U.S.A.	ON	ON	ON	#863 Canadian French	ON	ON	OFF
#850 Multi-lingual	OFF	ON	ON	#865 Nordic	OFF	ON	OFF
#860 Portuguese	ON	OFF	ON	(Reserved)	ON	OFF	OFF
#861 Icelandic	OFF	OFF	ON	(Reserved)	OFF	OFF	OFF

International character sets differ in their assignment of 12 character codes in the Standard Italic character set. See the character tables in Chapter 11. With these switches you can select one of eight character sets as follows:

Country	D-2	D-3	D-4	Country	D-2	D-3	D-4
U.S.A.	ON	ON	ON	Denmark I	ON	ON	OFF
France	OFF	ON	ON	Sweden	OFF	ON	OFF
Germany	ON	OFF	ON	Italy	ON	OFF	OFF
England	OFF	OFF	ON	Spain I	OFF	OFF	OFF

Switch D-5: CR Centering

If you set this switch OFF, the carriage moves to the center each time to feed paper near the perforation. This way, you can get better quality of printing around the perforations. It is recommended to match the page length setting to your fanfold paper, otherwise, this function does not work properly at the perforations.

If you leave this switch ON, the carriage does not move when feeding paper.

Switches E-1 to E-5: LQ Font Selection

These switches allow you to choose the default font selected when LQ mode is selected, as shown below.

Font Name	E-1	E-2	E-3	E-4	E-5	Font Name	E-1	E-2	E-3	E-4	E-5
Roman	ON	ON	ON	ON	ON	UPC/EAN*	ON	ON	ON	ON	OFF
Sanserif	OFF	ON	ON	ON	ON	Old-Style*	OFF	ON	ON	ON	OFF
Courier	ON	OFF	ON	ON	ON	Firenze*	ON	OFF	ON	ON	OFF
Prestige	OFF	OFF	ON	ON	ON	(Reserved)	OFF	OFF	ON	ON	OFF
Script	ON	ON	OFF	ON	ON	(Reserved)	ON	ON	OFF	ON	OFF
OCR-B*	OFF	ON	OFF	ON	ON	(Reserved)	OFF	ON	OFF	ON	OFF
OCR-A*	ON	OFF	OFF	ON	ON	(Reserved)	ON	OFF	OFF	ON	OFF
Orator*	OFF	OFF	OFF	ON	ON	(Reserved)	OFF	OFF	OFF	ON	OFF
Orator 2*	ON	ON	ON	OFF	ON	SLQ Roman*	ON	ON	ON	OFF	OFF
TW-Light*	OFF	ON	ON	OFF	ON	SLQ TW-Light*	OFF	ON	ON	OFF	OFF
Letter-Gothic*	ON	OFF	ON	OFF	ON	SLQ Script*	ON	OFF	ON	OFF	OFF
Blippo*	OFF	OFF	ON	OFF	ON	(Reserved)	OFF	OFF	ON	OFF	OFF
H-Gothic*	ON	ON	OFF	OFF	ON	(Reserved)	ON	ON	OFF	OFF	OFF
Orane*	OFF	ON	OFF	OFF	ON	(Reserved)	OFF	ON	OFF	OFF	OFF
Cinema*	ON	OFF	OFF	OFF	ON	(Reserved)	ON	OFF	OFF	OFF	OFF
Code 39*	OFF	OFF	OFF	OFF	ON	(Reserved)	OFF	OFF	OFF	OFF	OFF

Optional fonts (marked with*) can be selected only when the corresponding font cartridge is installed in the printer.

If the corresponding font cartridge is not installed, the Roman is selected.

Switch F-1: EDS Setting

If you set this switch OFF, the current EDS settings are all cleared, and restores the Factory Settings.

MEMO

Chapter 6

TROUBLESHOOTING

This chapter helps you identify printer conditions and problems that you can often correct yourself.

Remember that your printer is a highly sophisticated electronic device, which also contains high voltage inside. For that reason, only carry out those operations described in this chapter.

CAUTION: Any attempt to carry out operations other than those described here may result in electric shock and/or damage to the printer. When carrying out any repairs or maintenance, always follow the instructions carefully.

TROUBLESHOOTING

Your printer is a reliable piece of precision machinery, which should not cause you any trouble, provided it is used and treated sensibly. However, the few elementary tips below should help you avoid having to make unnecessary service calls.

- Power switch is on, but power indicator is off

Probable Cause	Action
Printer is not getting power.	Make sure that the power cord is correctly connected. Verify that the power source works.

- Printer sounds as if it is printing but does not; Printing is weak

Probable Cause	Action
Ribbon is jamming, twisted, or not between the print head and the print head shield.	Make sure that the ribbon cartridge is correctly installed. Make sure that the ribbon is between the shield on the print head and the end of the print head. Replace the ribbon.
Adjustment lever is set incorrectly.	Check the setting of the adjustment lever. Move the lever to a darker setting.

- Printer test works, but printer does not print when attached to computer

Probable Cause	Action
Printer cable has a problem.	Make sure that the printer cable is correctly connected at both ends, printer and computer.
Problem with the application program.	Refer to your application program manual.
Incorrect emulation is selected.	Select the other emulation with the EDS setting. See Chapter 5.

- Printer sounds the audible alarm

Probable Cause	Action
This might indicate an error or normal operation.	Check the message on the display and the status of the control panel indicators and see “Conditions indicated by messages and tones” in Chapter 4.

- Pitch or font selected is being changed

Probable Cause	Action
Your software is overriding your control panel selection.	Set your printer in Font/Pitch lock. See “Pitch lock mode” and “Font lock mode” in Chapter 4.

- Printer does not feed paper

Probable Cause	Action
Paper is jamming.	Remove all forms and pieces of paper.
Bail lever is closed before paper goes through the bail lever location.	Open the bail lever. Bail lever automatically closed when the paper goes through the bail lever location.
Adjustment lever is set incorrectly.	Check the setting of the adjustment lever. See “Adjusting the printing gap” in Chapter 3.
Fanfold form is parked.	Move bail lever forward to unpark the fanfold paper.

- Line spacing is incorrect or overprinting occurs

Probable Cause	Action
The tractor positions are incorrectly adjusted.	Adjust the tractor positions. See “Loading fanfold forms” in Chapter 3.
Incorrect emulation is selected.	Select the other emulation with the EDS setting. See Chapter 5.
Problem with the application program.	Refer to your application program manual.
Platen knob was manually turned while the Power indicator was on.	Set the top of form. See “Top of form” in Chapter 4. Do not manually turn the platen knob when the power is on. Use the <input type="button" value="PAPER FEED"/> button.
Forms are jamming between printing surface and the print head.	Reset adjustment lever. See “Adjusting the printing gap” in Chapter 3.

- Incorrect number of lines on a page

Probable Cause	Action
Paper is adjusted incorrectly.	Set the top of form. See “Top of form” in Chapter 4.
Paper has shifted backwards after several forms printed correctly.	Readjust forms.
Incorrect emulation is selected.	Select the other emulation with the EDS setting. See Chapter 5.
Problem with the application program.	Refer to your application program manual.
Distance printer must pull paper is too far.	Move paper closer to the printer.
Paper is getting stuck on cables.	Move the paper away from any wires or cables.

- Line length is wrong; Graphics do not print; Lines are not starting at left margin

Probable Cause	Action
Incorrect emulation is selected.	Select the other emulation with the EDS setting. See Chapter 5.
Problem with the application program.	Refer to your application program manual.

- Characters are wrong or missing; formatting control codes do not work

Probable Cause	Action
Problem with the application program.	Refer to your application program manual.
Some wires are missing from the print head.	Printer needs repair.
Wrong default setting with EDS switches.	Check the current EDS setting. Modify the EDS setting.

- Dots are missing or print quality is poor

Probable Cause	Action
Adjustment lever is set incorrectly.	Check the position of the adjustment lever. See Chapter 3.
Print head is not working.	Printer needs repair.

- Forms are smudged or printing is too dark

Probable Cause	Action
Adjustment lever is set incorrectly.	Check the position of the adjustment lever. Move the lever to a lighter setting (front). See Chapter 3.
Ribbon is twisted or is not between the print head and the print head shield.	Install the ribbon correctly. See “Installing the ribbon cartridge” in Chapter 2.
Print head shield (or print head) is damaged or missing.	See “Installing the ribbon cartridge” in Chapter 2 to locate the print head shield and print head. Contact your dealer.

- Printer is unstable; Wrong characters are printed; Left margin changes; printing stops

Probable Cause	Action
Static electricity is resulting from low humidity or interference from nearby electrical devices.	Increase the humidity. Move devices with electric motors away from the printer.

- Left margin moves to the right during printing

Probable Cause	Action
The print head is not moving correctly.	Check that the ribbon and paper are correctly installed. See “Installing ribbon cartridge” in Chapter 2 and “Loading paper” in Chapter 3.
Problem with the application program.	Refer to your application program manual.
The adjustment lever is in the wrong position.	Reset the adjustment lever. See “Adjusting the printing gap” in Chapter 3.

- Printer is printing beyond side edge of forms

Probable Cause	Action
Paper is adjusted incorrectly.	Adjust both forms tractors and the paper.
Problem with the application program.	Refer to your application program manual.
A print head jam caused by the ribbon or a paper jam.	Make sure that the ribbon cartridge is correctly installed. See “Installing the ribbon cartridge” in Chapter 2. Clear the paper jam.

- Printer case is hot to the touch

Probable Cause	Action
Printer's vents are blocked.	Move object away from the air vents, including the bottom of the printer.

- Printer is noisy

Probable Cause	Action
The printer vibrates.	Move any objects that touch the printer. Ensure that the printer is on a level, sturdy surface.
Printer covers are open.	Close covers.

MAINTENANCE

Essentially, your printer is a robust piece of equipment, but should be treated with a modicum of care in order to avoid malfunctions. For example:

- Keep your printer in a “comfortable” environment. Roughly speaking, if you are comfortable, then the environment is suitable for your printer (see Chapter 2).
- Do not subject the printer to physical shocks or excessive vibration.
- Avoid over-dusty environments. Dust is the enemy of all precision mechanical devices.
- To clean the exterior of the printer, use a cloth barely dampened with either water with a little detergent or a little alcohol, but do not allow any liquid to fall inside the printer.
- The interior of the printer may be cleaned with a small vacuum cleaner or a compressed-air aerosol (sold for this purpose). When performing this operation, be sure not to bend or damage any cable connections or electronic components.

Chapter 7

OPTIONAL ACCESSORIES

You can select the following accessories as option.

- Automatic sheet feeder (SF-10DS)
- Pull tractor unit (PT-10ZS)
- Font cartridges (FC series)
- RAM cartridge (RC-32Z, DC-32Z)
- Serial-Parallel Converter (SPC-8K)

This chapter describes how to install and use these optional accessories.

NOTE: When you install or remove the optional accessories, turn off the power switch.

AUTOMATIC SHEET FEEDER (SF-10DS)

You can use the Automatic Sheet Feeder (ASF) to print on cut-sheet forms.

Before installing the ASF, check each item in the box against Figure 7-1 to make sure that you have everything.

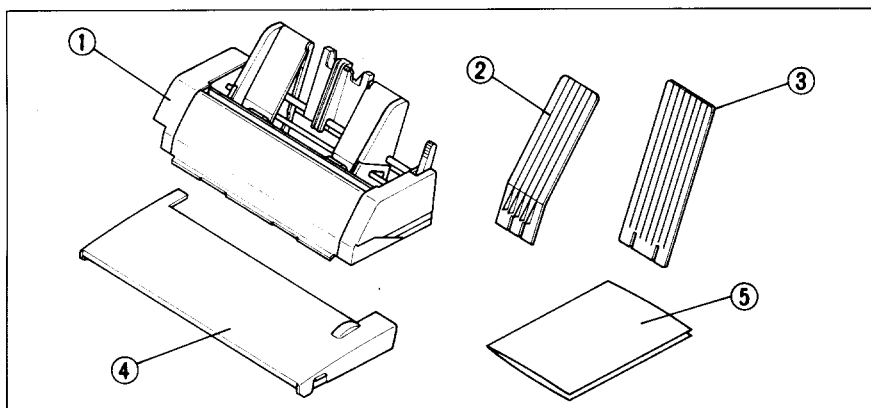

Figure 7-1. Check to make sure you have all five items: 1) Sheet Feeder, 2) Hopper attachment, 3) Stacker attachment, 4) Printer cover, and 5) ASF Users manual.

NOTE: The Automatic Sheet Feeder is protected by packing and tape during shipping. Be sure to remove all of the protective material and tape before use.

Setting up

The procedure to install the ASF is:

1. Use the printer's EDS mode to select ASF as "installed". (For details, please refer to Chapter 5.)
2. Open the front cover by lifting up the back using the two grips on either side, then remove the cover by pulling up.
3. Open the rear cover by lifting up the front using the two grips on either side.
4. Move the printer bail lever toward the front of the printer to open the paper bail.

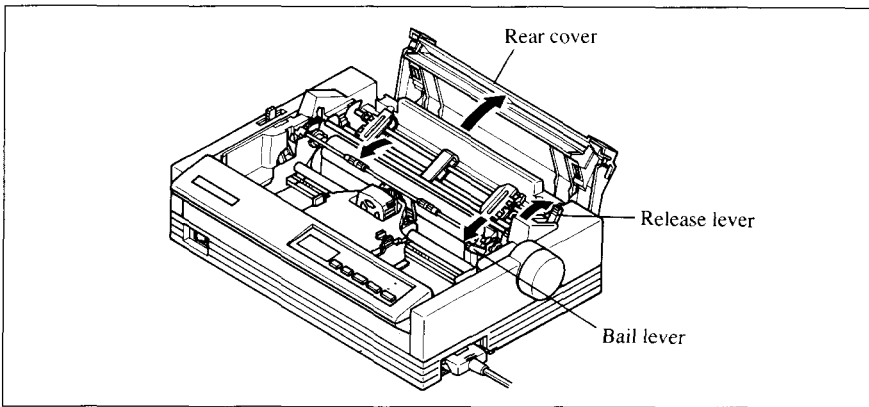

Figure 7-2. Remove the front cover, and open the rear cover.

5. Tip the Automatic Sheet Feeder forward slightly by aligning the notches on the ASF cover with the bail rollers, then put the feeder into place behind the printer platen roller.

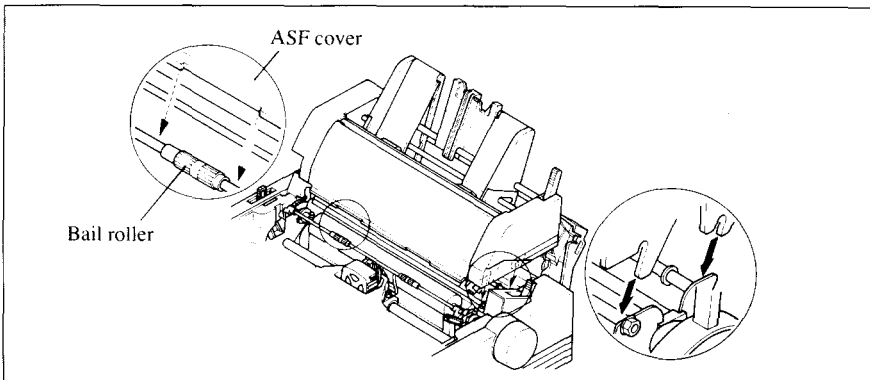

Figure 7-3. Align the notches and the bail rollers, then tip the ASF forward slightly.

6. Lower the rear side of the Automatic Sheet Feeder and attach it to the holder shaft.
7. Install the printer cover provided with the Automatic Sheet Feeder.

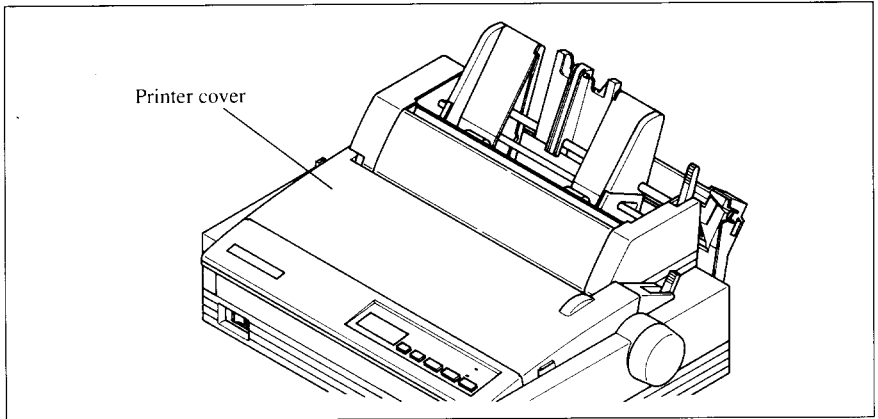

Figure 7-4. Install the printer cover.

8. Insert the hopper attachment on top of the hopper support section as shown in Figure 7-5.

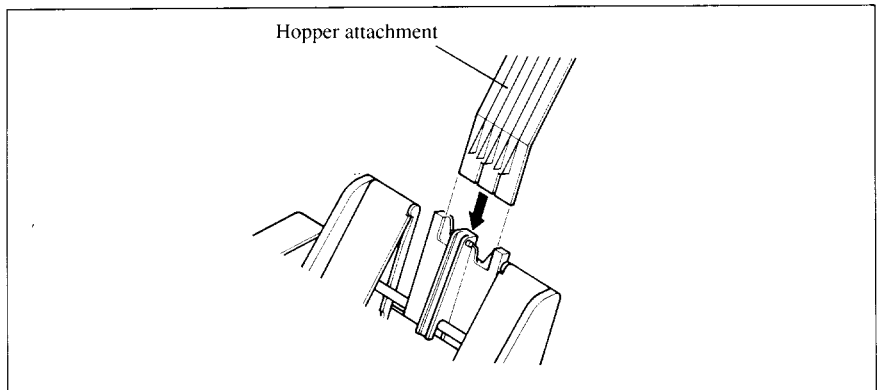

Figure 7-5. Insert the hopper attachment.

9. Insert the stacker attachment into the holder on the front part of the sheet feeder.

NOTE: The flat side of the attachment should be located to the rear, as shown in Figure 7-6.

Now, you can use the ASF by installing the paper stack into the hopper.

NOTE: Set the front cover aside carefully after they have been removed from the printer. Reverse the procedure described above when removing the Automatic Sheet Feeder.

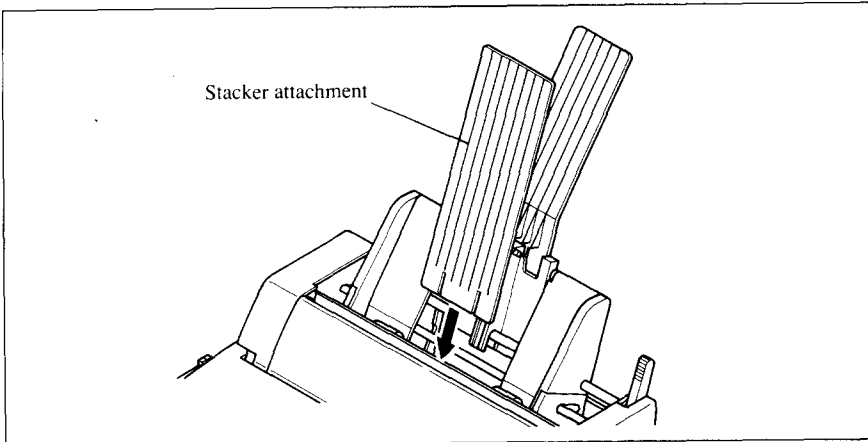



Figure 7-6. Insert the stacker attachment.

Loading paper

1. If fanfold paper has already been loaded in the printer, park the paper through the rear slot.
2. Push the printer release lever toward the rear of the printer () to load single sheets.
3. Pull the paper loading lever toward the front of the printer to pull the hopper out until it is in position.

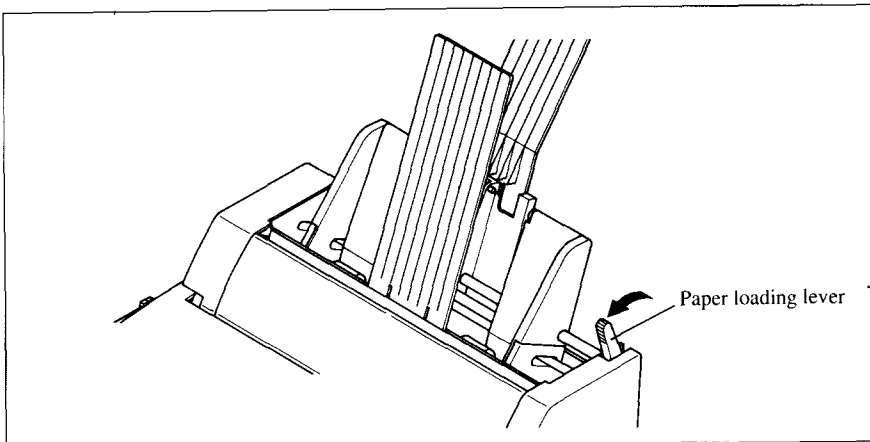

Figure 7-7. Pull the paper loading lever forward.

- Adjust the left paper guide to the desired left position by moving it horizontally in either direction.

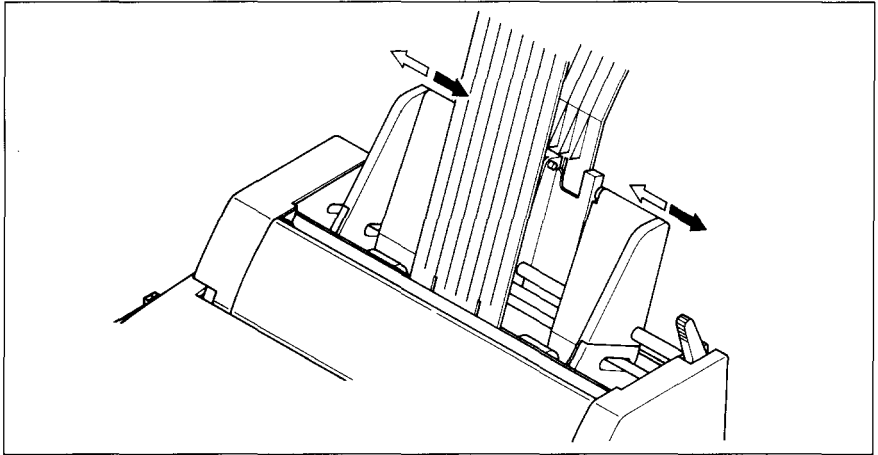

Figure 7-8. Adjust the paper guides to accommodate the width of the paper.

- Adjust the right paper guide to accommodate the width of the paper. The guides should be adjusted to restrict the amount of horizontal play while allowing the paper to slide up and down freely between the two paper guides. The ideal distance between paper ream and paper guides is 0.25 mm (0.01") on both sides at the narrowest part of the paper guides.
- Fan the paper stack and square it off properly before inserting it into the Automatic Sheet Feeder.

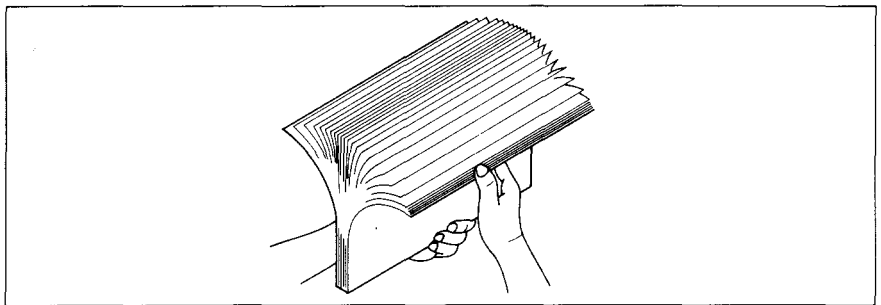

Figure 7-9. Fan the paper before inserting into the ASF.

- Insert the paper stack into the Automatic Sheet Feeder. The stack should not be more than 50 sheets of 20 lb paper. If necessary, remove some sheets. The ASF may not perform satisfactorily if it is overloaded.

8. Push the paper loading lever toward the rear of the printer.

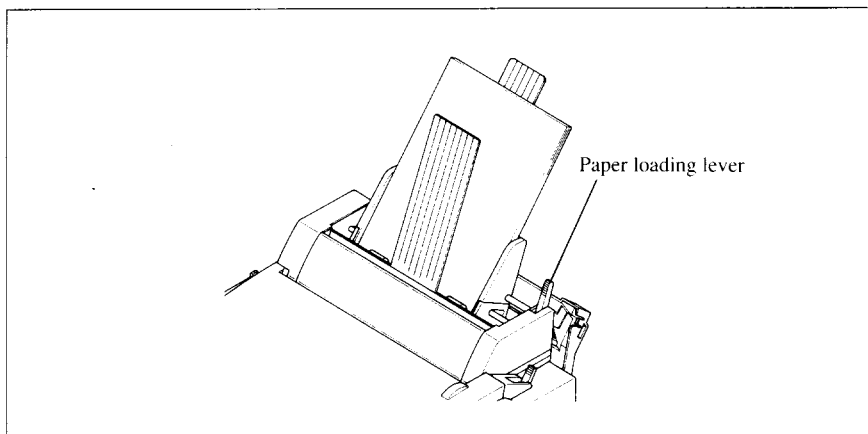

Figure 7-10. Push the paper loading lever to hold the paper stack.

Now, you are ready to start printing with the Automatic Sheet Feeder.

Feeding a single sheet

A single sheet of paper can also be fed manually with the Automatic Sheet Feeder.

1. Set the paper by inserting into the slot at the front of the stacker attachment, as shown in Figure 7-11.

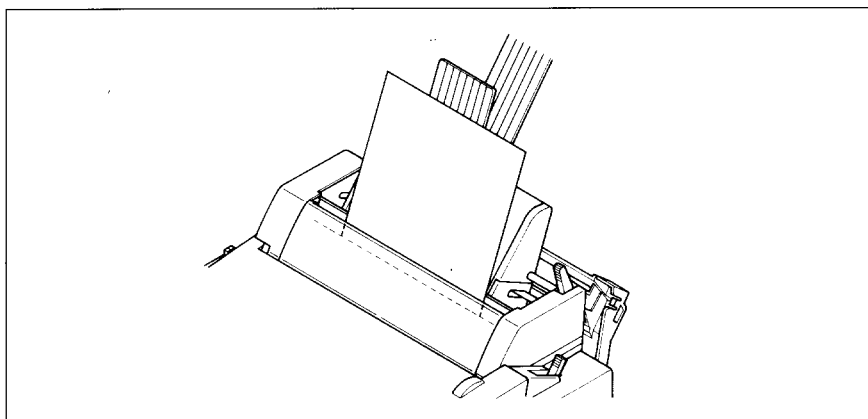

Figure 7-11. Insert a single sheet into the slot at the front of the stacker attachment.

2. With the power on, press the button to put the printer off-line. Then press the button. The paper will feed into the printer.

PULL TRACTOR UNIT (PT-10ZS)

You can use the Pull Tractor Unit to print on fanfold forms or multi-part forms through the bottom feed slot.

Setting up

The procedure to mount the Pull Tractor Unit is:

1. Open the front cover by lifting up the back using the two grips on either side, then remove it.
2. Open the rear cover by lifting up the front using the two grips on either side.
3. Move the printer bail lever toward the front of the printer to open the paper bail.
4. Fit the mounting brackets of the Pull Tractor Unit onto the shaft of the printer mechanism, tilting the Pull Tractor Unit slightly backward.

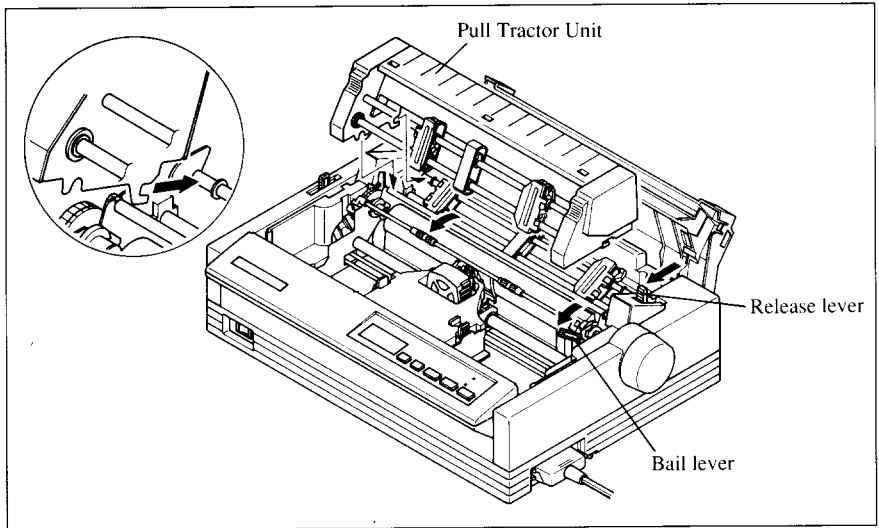

Figure 7-12. Fit the mounting brackets of the Pull Tractor Unit onto the shaft of the printer.

5. Secure the Pull Tractor Unit firmly by pushing the lock levers on either side, as shown in Figure 7-13.

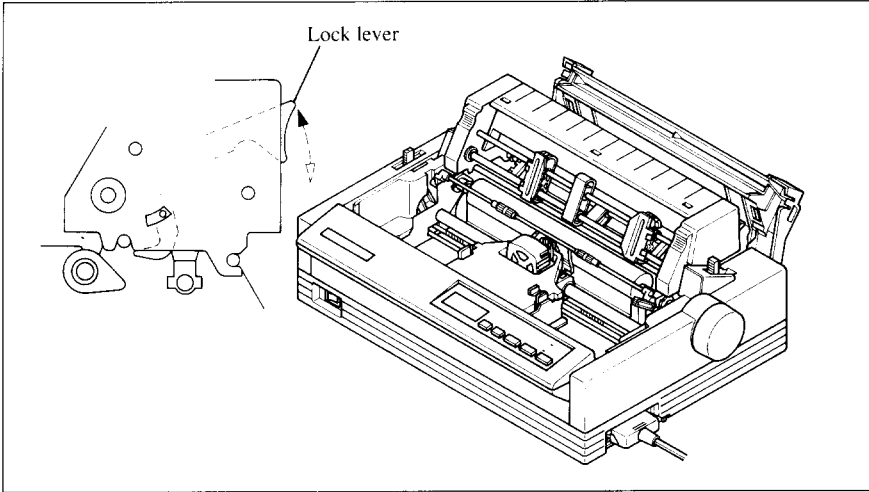

Figure 7-13. Install the Pull Tractor Unit onto the printer by pushing the lock levers.

6. Install the paper guide provided with the Pull Tractor Unit, as shown in Figure 7-14.
7. Install the printer cover provided with the Pull Tractor Unit.

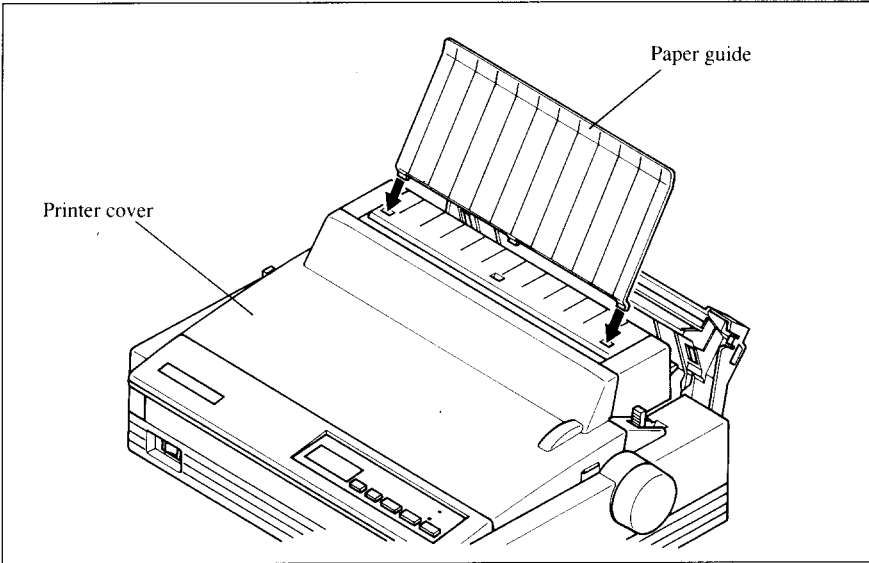

Figure 7-14. Mount the paper guide and the printer cover onto the printer.

NOTE: Set the paper guide and front cover aside carefully after they have been removed from the printer. Reverse the procedure described above when removing the Pull Tractor Unit.

Loading paper

1. Open the printer cover.
2. With the tractor covers open, guide the paper from the bottom of the printer, by aligning holes with the pins on the tractor unit.

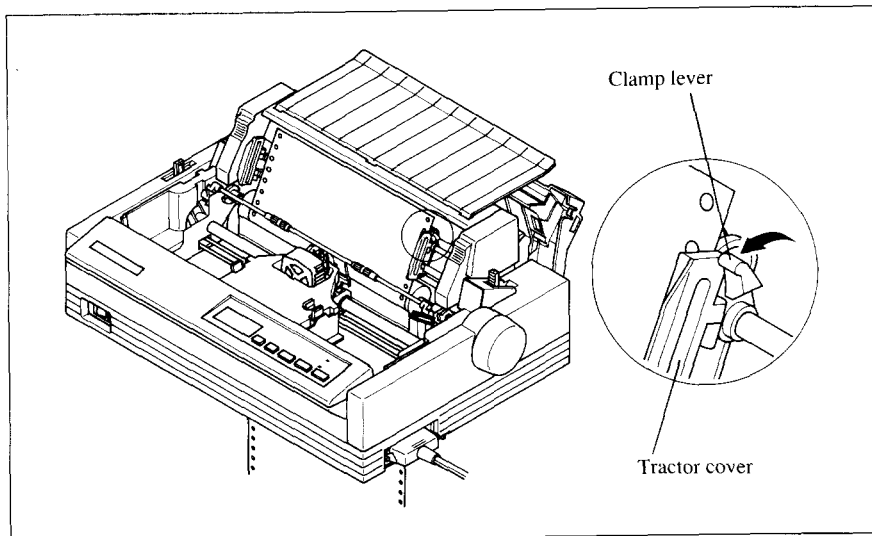

Figure 7-15. Mount the fanfold paper from the bottom of the printer.

3. Adjust the spacing of the tractor units by sliding them along the bar, using the clamp lever at the back of each unit to release and lock them in position. When the lever is up, the unit is released, and when it is down, the unit is locked.
4. Now close the tractor covers, again making sure that the paper holes are aligned with the pins on the tractor units. If they are not aligned properly, you will have problems with paper feeding, possibly resulting in tearing and jamming of the paper.

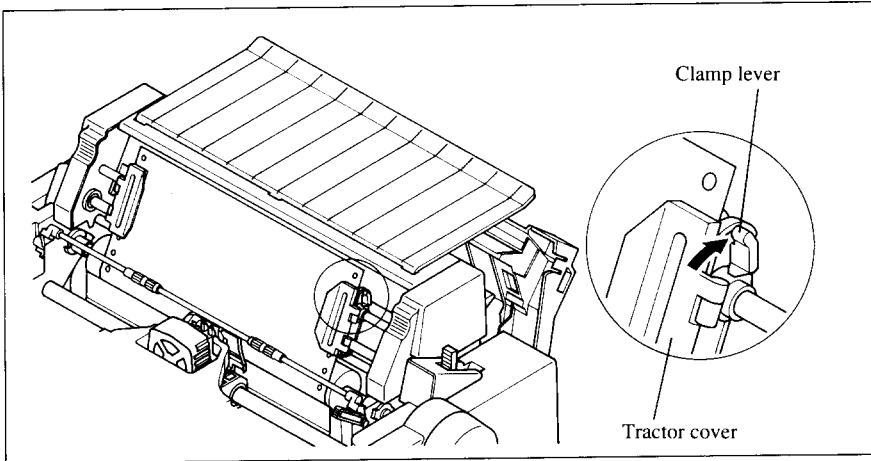

Figure 7-16. Close the tractor covers after adjust the spacing of the tractor units by sliding them along the bar.

5. After setting up the paper from the bottom of the printer, install the printer cover.

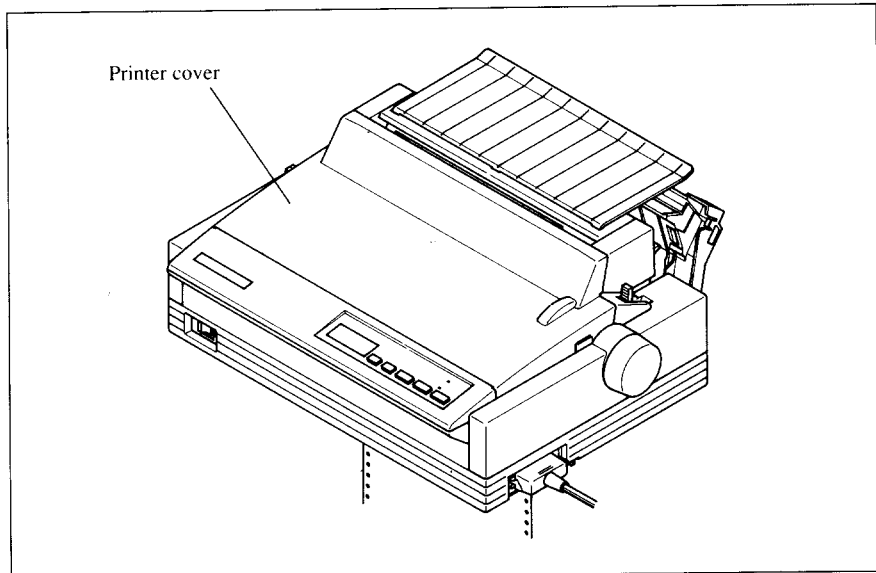

Figure 7-17. Mount the printer cover.



Now, you are ready to start printing with the Pull Tractor Unit.

FONT CARTRIDGES AND RAM CARTRIDGES

This printer has five built-in LQ fonts, and a 16 K-byte printing buffer.

You can add the following optional fonts or expand the printing buffer by installing optional cartridges (Font Cartridge or RAM Cartridge).

[Optional Font Cartridges]

	Font Name	Character sample
• FC-1Z	Orator	123456789 ABCDE ABCDE
	Orator 2	123456789 ABCDE abcde
	Letter Gothic	123456789 ABCDE abcde
	Blippo	123456789 ABCDE abcde
	Cinema	123456789 ABCDE abcde
• FC-2Z	OCR-B	123456789 ABCDE abcde
	OCR-A	123456789 ABCDE abcde
	CODE 39	
	UPC/EAN	123456789 12345 
• FC-3Z	TW-Light	123456789 ABCDE abcde
	H-Gothic	123456789 ABCDE abcde
	Orane	123456789 ABCDE abcde
• FC-4Z	Russian Roman	123456789 АБВГД ≡±∓∫
	GOST	123456789 рәëïï ПЯРСТ
	Cyrillic	123456789 АБВГД Èè€€Ï
• FC-5Z	Old Style	123456789  abcde
	Firenze	123456789 ABCDE abcde
• FC-10Z	SLQ Script	123456789 ABCDE abcde
• FC-11Z	SLQ Roman	123456789 ABCDE abcde
• FC-12Z	SLQ TW-Light	123456789 ABCDE abcde

[Optional RAM Cartridge]

- RC-32Z – 32 K-byte printing buffer with memory backup for downloading of data
- DC-32Z – 32 K-byte printing buffer

To install or change a cartridge, follow the procedure below.

1. Turn off the power switch at the front of the printer, and open the front cover.
2. Remove the connector cover at the right side of the printer.

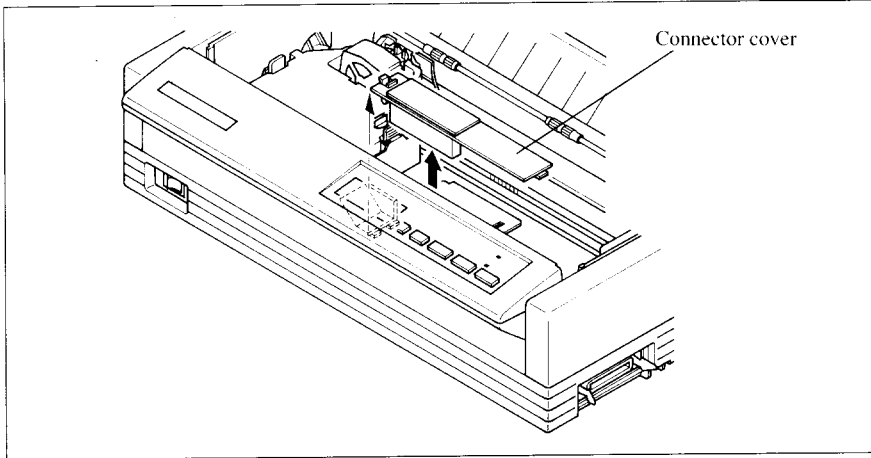

Figure 7-18. Remove the connector cover at the right side of the printer.

3. Push out the cap from the connector cover, as shown in Figure 7-19.
NOTE: Keep this cap in a safe place.

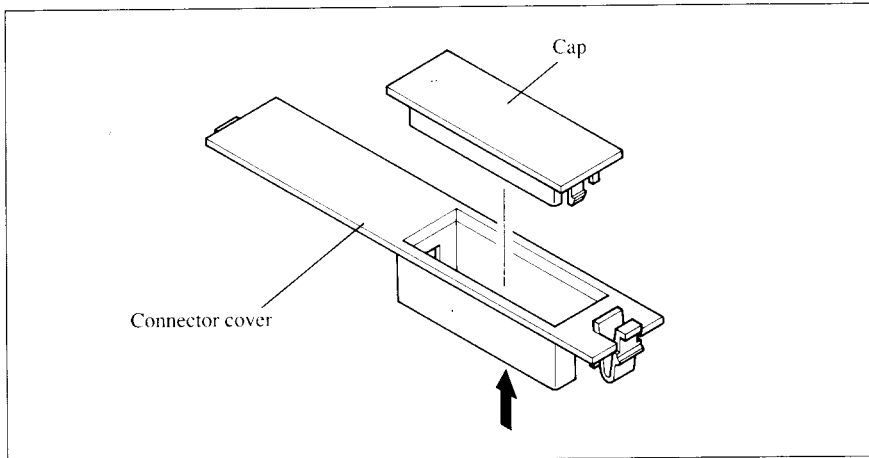

Figure 7-19. Push out the cap from the connector cover.

4. Install the connector cover into the printer.

5. Insert the cartridge into the slot of the connector cover, and slide it all the way in.

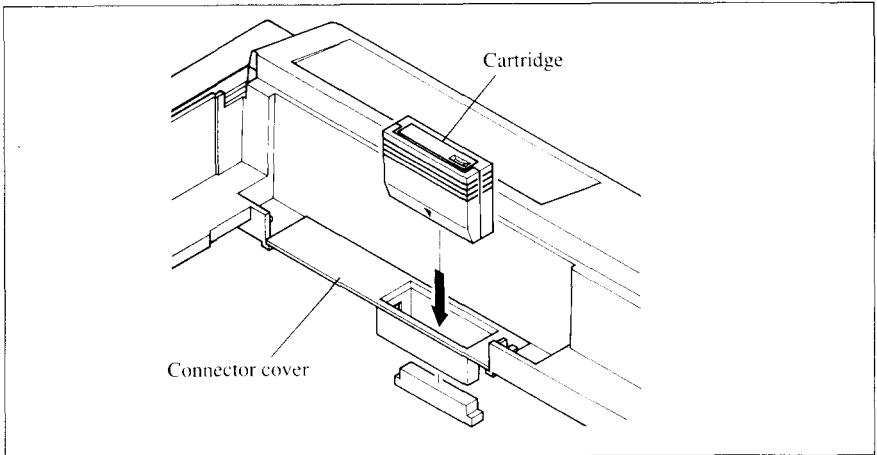

Figure 7-20. Insert the cartridge into the slot of the connector cover.

6. Close the front cover.

NOTE: Remount the cap on the connector cover if you are not using an optional cartridge.

INTERFACE CONVERTER (SPC-8K)

To run the printer in serial mode, you should use the optional Serial/Parallel Converter (SPC-8K).

The procedure to install the Converter is:

1. Set the DIP switches on the SPC-8K before attaching it to the printer. (See next page for detailed information.)
2. Turn off the power switch and disconnect the power cord from the power source.
3. Disconnect the interface cable if attached.
4. Connect the Parallel connector to the printer.
5. Move both clips inside the extended prongs on the sides of the plug until you hear a click.

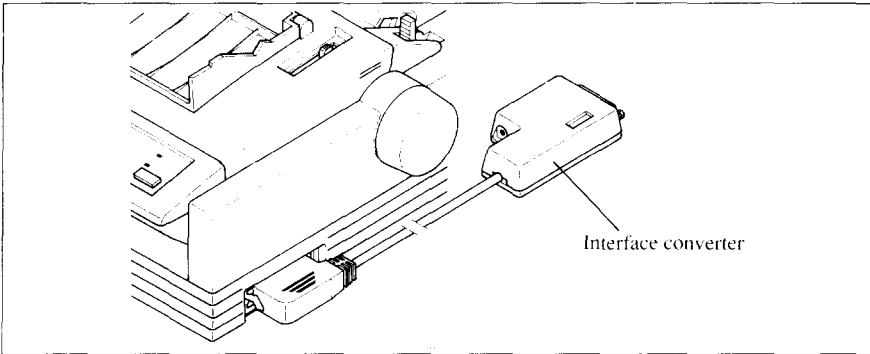

Figure 7-21. Connect the Parallel connector to the printer.

6. Connect the Serial connector to your computer.

NOTE: Place the Converter on a table in order not to damage the cable.

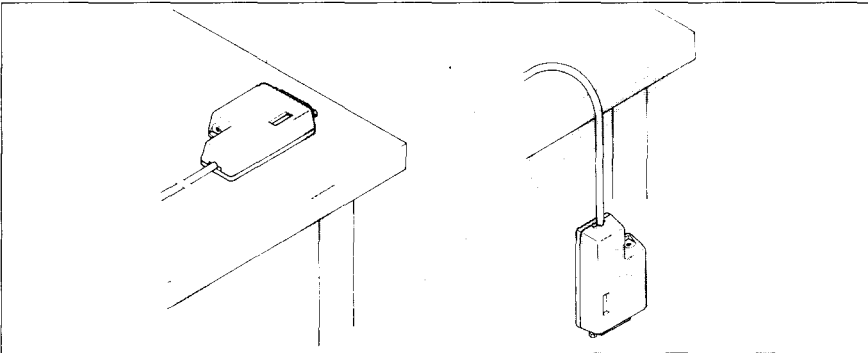

Figure 7-22. Place the converter on a table.

DIP Switch Functions on The Converter

It is necessary to make compatible the data transfer conditions between the computer and the serial interface board with the DIP switch settings on the converter.

Following table shows the functions of the DIP switches on the Serial-Parallel Converter.

Switch	Function	ON	OFF
1	Data length	8-bit	7-bit
2	Parity condition	(Refer below)	
3	Data Protocol	(Refer below)	
4			
5	Parity condition	(Refer below)	
6	Transfer speed	(Refer below)	
7			
8			

[Parity condition]

Switch 2	Switch 5	Condition
ON	ON	No parity
ON	OFF	
OFF	ON	Odd parity
OFF	OFF	Even parity

[Data protocol]

Switch 3	Switch 4	Protocol
ON	ON	DTR
ON	OFF	XON/XOFF
OFF	ON	ETX/ACK

[Transfer speed]

Switch 6	Switch 7	Switch 8	Transfer speed
OFF	OFF	OFF	150 BPS
OFF	OFF	ON	300 BPS
OFF	ON	OFF	600 BPS
OFF	ON	ON	1200 BPS
ON	OFF	OFF	2400 BPS
ON	OFF	ON	4800 BPS
ON	ON	OFF	9600 BPS
ON	ON	ON	19200 BPS

MEMO

Chapter 8

PRINTER CONTROL COMMANDS

The printer has two emulation modes: Standard/Epson mode and IBM mode.

In Standard/Epson mode, the printer emulates the functions of the Epson LQ-860/850, and the graphics commands for NEC 24-wire printers. In IBM mode, the printer emulates the IBM Proprinter X24E/24P and PS/1 printer. Additional command codes are included as a superset of these emulations.

The emulation is changed by means of EDS switch A-1. When it is ON, the printer will be in Standard/Epson mode, and when OFF, the printer will be in IBM mode (see Chapter 5).

In addition, when the EDS switch A-2 is ON, the printer automatically changes the emulation by means of software control.

This chapter describes the printer's control commands. Some commands are common to both the standard and IBM modes. In the descriptions of the commands, all commands will given by functions. The name of each command is followed by a table like the one below:

Mode	ASCII	Decimal	Hexadecimal
Std.	<ESC> "x" <l>	27 120 1	1B 78 01

Mode: Indicates the mode in which the command is recognized.

Std. Standard/Epson mode (EDS switch A-1 is ON.)

IBM IBM mode (EDS switch A-1 is OFF.)

Both Both Standard/Epson and IBM modes

ASCII: Indicates the ASCII coding of the command. Control characters are enclosed in pointed brackets: For example, <l> means character code l.

Decimal: Gives the command in decimal character codes.

Hexadecimal: Gives the command in hexadecimal character codes.

Parameters for which values must be supplied are indicated by italic letters such as *n*, *m* or *d*.

FONT CONTROL COMMANDS

Select print quality

Mode	ASCII	Decimal	Hexadecimal
Std.	<ESC> "x" <i>n</i>	27 120 <i>n</i>	1B 78 <i>n</i>

Changes the print quality according to the value of *n*, as shown below:

<i>n</i>	Print quality
0	Draft
1	Letter quality

Ignored if the FONT LOCK mode was selected during power-up.

Select print quality

Mode	ASCII	Decimal	Hexadecimal
IBM	<ESC> "[" "d" <1> <0> <i>n</i>	27 91100 1 0 <i>n</i>	1B 5B 64 01 00 <i>n</i>

Changes the print quality according to the value of *n*, as shown below:

<i>n</i>	Print quality
0	Unchanged
1 - 127	Draft
128 - 254	Letter quality
255	Return to EDS setting

Ignored if the FONT LOCK mode was selected during power-up.

Select LQ font

Mode	ASCII	Decimal	Hexadecimal
Both	<ESC> "k" <i>n</i>	27 107 <i>n</i>	1B 6B <i>n</i>

Selects an LQ font according to the value of *n*. In draft mode, this command remains dormant and takes effect later when LQ is selected. Ignored if the FONT LOCK mode was selected during power-up or the corresponding Font Cartridge is not installed.

<i>n</i>	Font	<i>n</i>	Font
0	Roman	11	Blippo (FC-1Z)
1	Sanserif	12	H-Gothic (FC-3Z)
2	Courier	13	Orane (FC-3Z)
3	Prestige	14	Cinema (FC-1Z)
4	Script	15	CODE 39 (FC-2Z)
5	OCR-B (FC-2Z)	16	UPC/EAN (FC-2Z)
6	OCR-A (FC-2Z)	17	Old Style (FC-5Z)
7	Orator (FC-1Z)	18	Firenze (FC-5Z)
8	Orator 2 (FC-1Z)	32	SLQ Roman (FC-11Z)
9	TW-Light (FC-3Z)	33	SLQ TW-Light (FC-12Z)
10	Letter Gothic (FC-1Z)	34	SLQ Script (FC-10Z)

Select italic characters

Mode	ASCII	Decimal	Hexadecimal
Std.	<ESC> "4"	27 52	1B 34

Causes subsequent characters to be printed in italics.

Select upright characters

Mode	ASCII	Decimal	Hexadecimal
Std.	<ESC> "5"	27 53	1B 35

Stops italic printing and causes subsequent characters to be printed upright.

Emphasized printing

Mode	ASCII	Decimal	Hexadecimal
Both	<ESC> "E"	27 69	1B 45

Causes subsequent characters to be emphasized by adding extra thickness to vertical strokes.

Cancel emphasized printing

Mode	ASCII	Decimal	Hexadecimal
Both	<ESC> "F"	27 70	1B 46

Cancels emphasized printing.

Double-strike printing

Mode	ASCII	Decimal	Hexadecimal
Both	<ESC> "G"	27 71	1B 47

Causes subsequent characters to be printed in double-strike mode with a slight vertical paper motion in between, causing a thickening of horizontal strokes.

For bold print, use of double-strike is recommended in LQ mode, and combined use of emphasized and double-strike is recommended in draft mode.

Cancel double-strike printing

Mode	ASCII	Decimal	Hexadecimal
Both	<ESC> "H"	27 72	1B 48

Cancels double-strike printing.

Underlining

Mode	ASCII	Decimal	Hexadecimal
Both	<ESC> "—" <i>n</i>	27 45 <i>n</i>	1B 2D <i>n</i>

Causes subsequent characters to be underlined when *n* is 1, and stops underlining when *n* is 0. IBM block graphics characters and spaces skipped by horizontal tabulation are not underlined.

Overlining

Mode	ASCII	Decimal	Hexadecimal
IBM	<ESC> "—" <i>n</i>	27 95 <i>n</i>	1B 5F <i>n</i>

Causes subsequent characters to be overlined when *n* is 1, and stops overlining when *n* is 0. Spaces skipped by horizontal tabulation are not overlined.

Select score

Mode	ASCII	Decimal	Hexadecimal
Std.	<ESC> “(” “-” <3> <0> <1> <i>n1</i> <i>n2</i>	27 40 45 3 0 1 <i>n1</i> <i>n2</i>	1B 28 2D 03 00 01 <i>n1</i> <i>n2</i>

Start score according to the values of *n1* and *n2*, as shown below.

<i>n1</i>	Function	<i>n2</i>	Function
1	Underlining	0	Cancel score
2	Strike-through	1	Single continuous line
3	Overlining	2	Double continuous line
		5	Single broken line
		6	Double broken line

Select ornament character

Mode	ASCII	Decimal	Hexadecimal
Std.	<ESC> “q” <i>n</i>	27 113 <i>n</i>	1B 71 <i>n</i>

Selects an ornament character according to the value of *n*, as shown below.

<i>n</i>	Character
0	Normal
1	Outline
2	Shadow
3	Shadow and outline

Superscript

Mode	ASCII	Decimal	Hexadecimal
Both	<ESC> “S” <0>	27 83 0	1B 53 00

Causes subsequent characters to be printed as superscripts. Does not change the character pitch.

Subscript

Mode	ASCII	Decimal	Hexadecimal
Both	<ESC> "S" <I>	27 83 1	1B 53 01

Causes subsequent characters to be printed as subscripts. Does not change the character pitch.

Cancel superscript or subscript

Mode	ASCII	Decimal	Hexadecimal
Both	<ESC> "T"	27 84	1B 54

Stops printing superscripts or subscripts and returns to normal printing.

CHARACTER SET COMMANDS

Select standard character set

Mode	ASCII	Decimal	Hexadecimal
Both	<ESC> "t" <0>	27 116 0	1B 74 00
Std.	<FS> "I" <0>	28 73 0	1C 49 0

Selects the standard character set. This is the power-up default in Standard mode if EDS switch D-1 is set to OFF.

Select IBM character set

Mode	ASCII	Decimal	Hexadecimal
Both	<ESC> "t" <1>	27 116 1	1B 74 01
Std.	<FS> "I" <1>	28 73 1	1C 49 01

Selects an IBM character set. This is the power-up default in IBM mode, or EDS switch D-1 is set to ON in standard mode.

Select character set #1

Mode	ASCII	Decimal	Hexadecimal
Both	<ESC> "7"	27 55	1B 37

Selects character set #1.

Select character set #2

Mode	ASCII	Decimal	Hexadecimal
Both	<ESC> "6"	27 54	1B 36

Selects character set #2.

Select international character set

Mode	ASCII	Decimal	Hexadecimal
Std.	<ESC> "R" <i>n</i>	27 82 <i>n</i>	1B 52 <i>n</i>

Selects an international character set in the Standard character set according to the value of *n*.

<i>n</i>	Character set	<i>n</i>	Character set
0	U.S.A	8	Japan
1	France	9	Norway
2	Germany	10	Denmark II
3	England	11	Spain II
4	Denmark I	12	Latin America
5	Sweden	13	Korea
6	Italy	14	Irish
7	Spain I	64	Legal

The first eight of these character sets (from U.S.A. to Spain I) can be selected as power-up default by EDS switches D-2 to D-4.

Select IBM code page

Mode	ASCII	Decimal	Hexadecimal
Both	<ESC> "[" "T" <4> <0> <0> <0> <i>n1</i> <i>n2</i>	27 91 84 4 0 0 0 <i>n1</i> <i>n2</i>	1B 5B 54 04 00 00 00 <i>n1</i> <i>n2</i>

Changes the code page of the current IBM character set according to the values of *n1* and *n2*.

<i>n1</i>	<i>n2</i>	Code Page
1	181	#437 U.S.A.
3	82	#850 Multi-lingual
3	92	#860 Portuguese
3	93	#861 Icelandic
3	95	#863 Canadian French
3	97	#865 Nordic

One of these code pages can be selected as power-up defaults by EDS switches D-2 to D-4.

Enable printing of all character codes

Mode	ASCII	Decimal	Hexadecimal
Std.	<FS> “\” <i>n1 n2</i>	28 92 <i>n1 n2</i>	1C 5C <i>n1 n2</i>
IBM	<ESC> “\” <i>n1 n2</i>	27 92 <i>n1 n2</i>	1B 5C <i>n1 n2</i>

Enables printing of all characters in the IBM character set, including those assigned to character codes which are normally considered control codes. This command remains in effect for the next $n1 + n2 \times 256$ characters, where $n1$ and $n2$ are numbers between 0 and 255. During this interval no control functions are executed. If a code with no assigned character is received, the printer prints a space.

Enable printing of all character codes on next character

Mode	ASCII	Decimal	Hexadecimal
Std.	<FS> “^” <i>n</i>	28 94 <i>n</i>	1C 5E <i>n</i>
IBM	<ESC> “^” <i>n</i>	27 94 <i>n</i>	1B 5E <i>n</i>

This command operates like <ESC> “\” except that it remains in effect for only one character.

Select slash zero

Mode	ASCII	Decimal	Hexadecimal
Std.	<ESC> “~” <1>	27 126 1	1B 7E 01

Causes subsequent zero characters to be overprinted with a slash (\emptyset).

Select normal zero

Mode	ASCII	Decimal	Hexadecimal
Std.	<ESC> “~” <0>	27 126 0	1B 7E 00

Causes subsequent zero characters to be printed normally (0), without a slash.

CHARACTER SIZE AND PITCH COMMANDS

Pica pitch

Mode	ASCII	Decimal	Hexadecimal
Std.	<ESC> "P"	27 80	1B 50
IBM	<DC2>	18	12

In Standard mode, changes from either elite or semi-condensed to pica pitch (10 cpi) or from condensed elite to condensed pica (17 cpi). In IBM mode, changes from either elite or condensed to pica (10 cpi). Ignored if the PITCH LOCK mode was selected during power-up.

Elite pitch

Mode	ASCII	Decimal	Hexadecimal
Std.	<ESC> "M"	27 77	1B 4D
IBM	<ESC> ":",	27 58	1B 3A

Changes from either pica or semi-condensed to elite pitch (12 cpi) or from condensed pica to condensed elite (20 cpi). Ignored if the PITCH LOCK mode was selected during power-up.

Semi-condensed pitch

Mode	ASCII	Decimal	Hexadecimal
Std.	<ESC> "g"	27 103	1B 67

Changes from either pica or elite to semi-condensed pitch (15 cpi). Ignored if the PITCH LOCK mode was selected during power-up.

Condensed printing

Mode	ASCII	Decimal	Hexadecimal
Both	<SI>	15	0F
	<ESC> <SI>	27 15	1B 0F

Changes from pica to condensed pica (17 cpi) or from elite to condensed elite (20 cpi). Ignored if the PITCH LOCK mode was selected during power-up.

Cancel condensed printing

Mode	ASCII	Decimal	Hexadecimal
Both	<DC2>	18	12

In Standard mode, changes from condensed pica to normal pica or from condensed elite to normal elite. In IBM mode, always changes to normal pica. Ignored if the PITCH LOCK mode was selected during power-up.

Proportional spacing

Mode	ASCII	Decimal	Hexadecimal
Std.	<ESC> "p" <i>n</i>	27 112 <i>n</i>	1B 70 <i>n</i>
IBM	<ESC> "P" <i>n</i>	27 80 <i>n</i>	1B 50 <i>n</i>

Causes subsequent characters to be proportionally spaced when *n* is 1, and cancels it when *n* is 0. Ignored if the PITCH LOCK mode was selected during power-up.

Select font and pitch

Mode	ASCII	Decimal	Hexadecimal
IBM	<ESC> "[" "I" <2> <0> <i>n1 n2</i>	27 91 73 2 0 <i>n1 n2</i>	1B 5B 49 02 00 <i>n1 n2</i>

Changes the print font and pitch according to the values of *n1* and *n2*, as shown below.

<i>n1</i>	<i>n2</i>	Font and pitch	<i>n1</i>	<i>n2</i>	Font and pitch
0	11	10 CPI Courier	1	202	20 CPI Prestige
1	235	12 CPI Courier	1	31	24 CPI Prestige
1	236	15 CPI Courier	0	164	Proportional Prestige
1	237	17 CPI Courier	0	36	10 CPI Letter Gothic
1	238	20 CPI Courier	1	143	12 CPI Letter Gothic
1	30	24 CPI Courier	1	142	15 CPI Letter Gothic
0	171	Proportional Courier	1	141	17 CPI Letter Gothic
0	12	10 CPI Prestige	1	140	20 CPI Letter Gothic
1	239	12 CPI Prestige	1	32	24 CPI Letter Gothic
1	240	15 CPI Prestige	0	174	Proportional Letter Gothic
1	201	17 CPI Prestige			

Select font and pitch

Mode	ASCII	Decimal	Hexadecimal
IBM	<ESC> "I" <i>n</i>	27 73 <i>n</i>	1B 49 <i>n</i>

Changes the print font and pitch according to the values of *n*, as shown below.

<i>n</i>	Font and pitch	<i>n</i>	Font and pitch
0	10 CPI Draft	10	12 CPI Letter Quality
2	10 CPI Letter Quality	12	12 CPI Draft Download
3	Proportional Letter Quality	14	12 CPI LQ Download
4	10 CPI Draft Download	16	17 CPI Draft
6	10 CPI LQ Download	18	17 CPI Letter Quality
7	Proportional LQ Download	20	17 CPI Draft Download
8	12 CPI Draft	22	17 CPI LQ Download

Expanded printing

Mode	ASCII	Decimal	Hexadecimal
Both	<ESC> "W" <i>n</i>	27 87 <i>n</i>	1B 57 <i>n</i>

Causes subsequent characters to be expanded to double width when *n* is 1, and cancels it when *n* is 0.

Expanded printing for one line

Mode	ASCII	Decimal	Hexadecimal
Both	<SO>	14	0E
	<ESC> <SO>	27 14	1B 0E

Causes subsequent characters in the current line to be expanded to double width. Characters return to normal width after the next line feed (<LF>). The <DC4>, <VT>, <FF>, and <ESC> "W" 0 commands also cancel expanded printing.

Cancel one-line expanded printing

Mode	ASCII	Decimal	Hexadecimal
Both	<DC4>	20	14

Stops one-line expanded printing set with <SO> or <ESC> <SO>. Does not cancel <ESC> "W" 1.

Select character width

Mode	ASCII	Decimal	Hexadecimal
Std.	<FS> "E" <i>n</i>	28 69 <i>n</i>	1C 45 <i>n</i>

Select a character width according to the value of *n* as shown below.

<i>n</i>	Character width
0	Normal-wide
1	Double-wide
2	Triple-wide

Select master print mode

Mode	ASCII	Decimal	Hexadecimal
Std.	<ESC> "!" <i>n</i>	27 33 <i>n</i>	1B 21 <i>n</i>

Selects a combined print mode according to the value of *n*. The value of *n* is the sum of the values given below for the desired characteristics.

Function	<i>n</i> value
Underline	128
Italic	64
Expanded	32
Double strike	16
Emphasized	8
Condensed [*]	4
Proportional [*]	2
Elite [*]	1

[*] Ignored if the PITCH LOCK mode was selected during power-up.

Examples: $n = 1$ gives elite; $n = 9$ ($1 + 8$) gives emphasized elite; $n = 137$ ($1 + 8 + 128$) gives underlined emphasized elite.

Increase character spacing

Mode	ASCII	Decimal	Hexadecimal
Std.	<ESC> <SP> <i>n</i>	27 32 <i>n</i>	1B 20 <i>n</i>

Increases the space between characters by *n* dots, where *n* is a number from 0 to 127. Used in microjustification.

Select double or quadruple size

Mode	ASCII	Decimal	Hexadecimal
Std.	<ESC> "h" <i>n</i>	27 104 <i>n</i>	1B 68 <i>n</i>

Selects the size of subsequent characters as shown below. Extra-high characters align along the cap-line of normal characters, with the base line temporarily moving down. Line spacing is temporarily doubled when $n = 1$ and quadrupled when $n = 2$.

<i>n</i>	Effect
0	Normal size
1	Double-high, double-wide
2	Quadruple-high, quadruple-wide

Print double-height characters

Mode	ASCII	Decimal	Hexadecimal
Std.	<ESC> "w" <I>	27 119 1	1B 77 01
	<FS> "V" <I>	28 86 1	1C 56 01

Prints subsequent characters at double height without moving the base line, and without changing the line spacing.

Return to normal height

Mode	ASCII	Decimal	Hexadecimal
Std.	<ESC> "w" <O>	27 119 0	1B 77 00
	<FS> "V" <O>	28 86 0	1C 56 00

Terminates double-height printing and prints subsequent characters at normal height.

Select character height, width, and line spacing

Mode	ASCII	Decimal	Hexadecimal
IBM	<ESC> “[” “@” <4> <0> <0> <0> <i>n</i> <i>m</i>	27 91 64 4 0 0 0 <i>n</i> <i>m</i>	1B 5B 40 04 00 00 00 <i>n</i> <i>m</i>

Selects a combination of character height, width, and line spacing according to the value of *n* and *m*, as below. Does not move the base line.

<i>n</i>	Line spacing	Character height
0	Unchanged	Unchanged
1	Unchanged	Single height
2	Unchanged	Double height
16	Single	Unchanged
17	Single	Single height
18	Single	Double height
32	Double	Unchanged
33	Double	Single height
34	Double	Double height
<i>m</i>	Character width	
1	Single width (same as <ESC> “W” 0)	
2	Double width (same as <ESC> “W” 1)	

VERTICAL POSITION COMMANDS

Set line spacing to 1/8 inch

Mode	ASCII	Decimal	Hexadecimal
Both	<ESC> "0"	27 48	1B 30

Sets the distance the paper advances or reverses in subsequent line feeds to 1/8 inch.

Set line spacing to 7/60 or 7/72 inch

Mode	ASCII	Decimal	Hexadecimal
Both	<ESC> "1"	27 49	1B 31

Sets the distance the paper advances or reverses in subsequent line feeds to 7/60 inch (standard mode) or 7/72 inch (IBM mode).

Set line spacing to 1/6 inch

Mode	ASCII	Decimal	Hexadecimal
Std.	<ESC> "2"	27 50	1B 32

Sets the distance the paper advances or reverses in subsequent line feeds to 1/6 inch.

Set line spacing to n/360 inch

Mode	ASCII	Decimal	Hexadecimal
Std.	<ESC> "+" <i>n</i>	27 43 <i>n</i>	1B 2B <i>n</i>
	<FS> "3" <i>n</i>	28 51 <i>n</i>	1C 33 <i>n</i>

Sets the distance the paper advances or reverses in subsequent line feeds to $n/360$ inch, where n is between 0 and 255.

Set base unit for line spacing

Mode	ASCII	Decimal	Hexadecimal
IBM	<ESC> “[” “\” <4> <0>	27 91 92 4 0	1B 5B 5C 04 00
	<0> <0> <i>n1</i> <i>n2</i>	0 0 <i>n1</i> <i>n2</i>	00 00 <i>n1</i> <i>n2</i>

Sets the base unit for the line spacing commands, <ESC> “3” and <ESC> “J”, according to the values of *n1* and *n2* as shown below. If other values specified, this command is ignored. This command becomes effective only after <ESC> “3” or <ESC> “J” is received. The default base unit is set to 1/216”.

<i>n1</i>	<i>n2</i>	Base unit
0	180	1/180-inch
0	216	1/216-inch
1	104	1/360-inch

Set line spacing to *n*/180 inch, *n*/216 inch, or *n*/360 inch

Mode	ASCII	Decimal	Hexadecimal
Both	<ESC> “3” <i>n</i>	27 51 <i>n</i>	1B 33 <i>n</i>

Sets the distance the paper advances or reverses in subsequent line feeds to *n*/180 inch, *n*/216 inch, or *n*/360 inch, according to the defined base unit. The value of *n* is between 0 and 255. If *n*=0, in Standard mode the line-feed distance is set to 0, but in IBM mode this command is ignored.

Set line spacing to *n*/60 inch or *n*/72 inch

Mode	ASCII	Decimal	Hexadecimal
Both	<ESC> “A” <i>n</i>	27 65 <i>n</i>	1B 41 <i>n</i>

In Standard mode, sets the distance the paper advances or reverses in subsequent line feeds to *n*/60 inch, where *n* is between 0 and 255. If *n* = 0, the line spacing is set to 0.

In IBM mode this command defines the distance the paper advances or reverses in subsequent line feeds to *n*/72 inch, where *n* is between 1 and 85. The new line spacing does not take effect until next <ESC> “2” command.

Execute <ESC> “A”

Mode	ASCII	Decimal	Hexadecimal
IBM	<ESC> “2”	27 50	1B 32

Sets the line spacing to the value defined by the last preceding <ESC> “A” command. Sets the line spacing to 1/6 inch if there is no preceding <ESC> “A” command.

Line feed

Mode	ASCII	Decimal	Hexadecimal
Both	<LF>	10	0A

Prints the current line and feeds the paper to the next line. See the preceding commands for the line spacing.

Reverse line feed

Mode	ASCII	Decimal	Hexadecimal
Std.	<ESC> <LF>	27 10	1B 0A
IBM	<ESC> “J”	27 93	1B 5D

Prints the current line and feeds the paper in the reverse direction to the preceding line. See the preceding commands for the line spacing.

Select forward feed mode

Mode	ASCII	Decimal	Hexadecimal
Std.	<FS> “F”	28 70	1C 46

Cancels the reverse feed mode and selects forward feed mode. This is the default setting at power-on.

Select reverse feed mode

Mode	ASCII	Decimal	Hexadecimal
Std.	<FS> “R”	28 82	1C 52

Selects reverse feed mode. Reverses the direction of all vertical movements. Ignored when friction feed or bottom feed is used.

Perform one n/180-inch, n/216-inch, or n/360-inch line feed

Mode	ASCII	Decimal	Hexadecimal
Both	<ESC> "J" <i>n</i>	27 74 <i>n</i>	1B 4A <i>n</i>

Feeds the paper once by $n/180$ inches, $n/216$ inches, or $n/360$ inches, according to the defined base unit. The value of n is between 1 and 255. Does not move the print position right or left in the standard mode. Does not change the line-spacing setting.

Perform one n/180-inch reverse line feed

Mode	ASCII	Decimal	Hexadecimal
Std.	<ESC> "j" <i>n</i>	27 106 <i>n</i>	1B 6A <i>n</i>

Feeds the paper once by $n/180$ inches in the reverse direction, where n is between 1 and 255.

Does not move the print position right or left. Does not change the line-spacing setting.

Feed paper n lines

Mode	ASCII	Decimal	Hexadecimal
Std.	<ESC> "f" <l> <i>n</i>	27 102 1 <i>n</i>	1B 66 01 <i>n</i>

Feeds the paper n lines from the current line, where n is between 0 and 127.

Set top of page at current position

Mode	ASCII	Decimal	Hexadecimal
IBM	<ESC> "4"	27 52	1B 34

Sets the current position as the top-of-page position. Note that this can also be done from the control panel.

Set page length to n lines

Mode	ASCII	Decimal	Hexadecimal
Both	<ESC> "C" n	27 67 n	1B 43 n

Sets the page length to n lines in the current line spacing, where n is between 1 and 127.

Changing the line spacing later does not alter the physical page length. The current line becomes the top of the page.

Set page length to n inches

Mode	ASCII	Decimal	Hexadecimal
Both	<ESC> "C" <0> n	27 67 0 n	1B 43 00 n

Sets the page length to n inches, where n is between 1 and 32 in Standard mode or between 1 and 64 in IBM mode. The current line becomes the top of the page.

Set bottom margin

Mode	ASCII	Decimal	Hexadecimal
Both	<ESC> "N" n	27 78 n	1B 4E n

Sets the bottom margin to n lines, where n is between 1 and 127 in Standard mode or between 1 and 255 in IBM mode. The bottom margin is reset when you change the page length.

Cancel bottom margin

Mode	ASCII	Decimal	Hexadecimal
Both	<ESC> "O"	27 79	1B 4F

Cancels the bottom margin.

Form feed

Mode	ASCII	Decimal	Hexadecimal
Both	<FF>	12	0C

Feeds the paper to the top of the next page according to the current page length, and moves the print position to the left margin. When the automatic sheet feeder (ASF) is selected with EDS switch A-5, this command ejects the current page.

Return to top of current page

Mode	ASCII	Decimal	Hexadecimal
Std.	<ESC> <FF>	27 12	1B 0C

Feeds the paper backward to the top of the current page.

Disable paper-out detector

Mode	ASCII	Decimal	Hexadecimal
Both	<ESC> "8"	27 56	1B 38

Causes the printer to disregard the signal sent by the paper-out detector, enabling printing to the bottom of the paper. Overrides the setting of EDS switch B-2.

Enable paper-out detector

Mode	ASCII	Decimal	Hexadecimal
Both	<ESC> "9"	27 57	1B 39

Causes the printer to stop printing before the end of the paper. Overrides the setting of EDS switch B-2.

Set vertical tab stops

Mode	ASCII	Decimal	Hexadecimal
Both	<ESC> "B" $n1$ $n2$ <0>	27 66 $n1$ $n2$ 0	1B 42 $n1$ $n2$... 00

Cancels all current vertical tab stops and sets new vertical tab stops at lines $n1$, $n2$, etc., where $n1$, $n2$, etc. are numbers between 1 and 255. A maximum of 16 vertical tab stops can be set. The tab stops must be specified in ascending order; any violation of ascending order terminates the tab stop list. Standard termination is by the <0> control code. The vertical tab stops are set in terms of the current line spacing and do not move if the line spacing is changed later.

Set vertical tab stops every n lines

Mode	ASCII	Decimal	Hexadecimal
Std.	<ESC> "e" <l> n	27 101 1 n	1B 65 01 n

Cancels all current vertical tab stops and sets new tab stops every n lines, where n is between 2 and 127.

Set vertical tab stops in channel

Mode	ASCII	Decimal	Hexadecimal
Std.	<ESC> "b" $n0$ $n1$ $n2$ <0>	27 98 $n0$ $n1$ $n2$ 0	1B 62 $n0$ $n1$ $n2$... 00

Cancels all current vertical tab stops in channel $n0$, (where $n0$ is between 0 and 7) and sets new vertical tab stops in this channel. (A channel is a set of vertical tab stops selected by the <ESC> "f" command.) See <ESC> "B" for parameters $n1$, $n2$, ... <0>.

Select vertical tab channel

Mode	ASCII	Decimal	Hexadecimal
Std.	<ESC> "f" $n0$	27 47 $n0$	1B 2F $n0$

Selects a set of vertical tab stops designated by a channel number ($n0$) from 0 to 7. The tab stops in each channel are set by <ESC> "b".

Vertical tab

Mode	ASCII	Decimal	Hexadecimal
Both	<VT>	11	0B

Feeds the paper to the next vertical tab stop and moves the print position to the left margin. Performs a line feed if no vertical tabs are set, as at power-up. Feeds to the top of the next page if vertical tabs are set but the current line is at or below the last vertical tab stop.

HORIZONTAL POSITION COMMANDS

Set left margin

Mode	ASCII	Decimal	Hexadecimal
Std.	<ESC> "l" <i>n</i>	27 108 <i>n</i>	1B 6C <i>n</i>

Sets the left margin at column *n* (where *n* is between 0 and 255) in the current character pitch (pica pitch if proportional spacing is selected). The left margin does not move if the character pitch is changed later. The left margin must be at least two columns to the left of the right margin and within the limits below:

Pica	$0 \leq n \leq 76$
Elite	$0 \leq n \leq 91$
Semi-condensed	$0 \leq n \leq 114$
Condensed pica	$0 \leq n \leq 130$
Condensed elite	$0 \leq n \leq 152$
Expanded pica	$0 \leq n \leq 38$
Expanded elite	$0 \leq n \leq 45$
Expanded semi-condensed	$0 \leq n \leq 57$
Expanded condensed pica	$0 \leq n \leq 64$
Expanded condensed elite	$0 \leq n \leq 76$

Set right margin

Mode	ASCII	Decimal	Hexadecimal
Std.	<ESC> "Q" <i>n</i>	27 81 <i>n</i>	1B 51 <i>n</i>

Sets the right margin at column *n* in the current character pitch (pica pitch if proportional spacing is currently selected). Column *n* becomes the last character position in the line.

The right margin does not move if the character pitch is changed later. The right margin must be within the limits below:

Pica	$4 \leq n \leq 80$
Elite	$5 \leq n \leq 96$
Semi-condensed	$6 \leq n \leq 120$
Condensed pica	$7 \leq n \leq 137$
Condensed elite	$8 \leq n \leq 160$
Expanded pica	$2 \leq n \leq 40$
Expanded elite	$3 \leq n \leq 48$
Expanded semi-condensed	$3 \leq n \leq 60$
Expanded condensed pica	$4 \leq n \leq 68$
Expanded condensed elite	$4 \leq n \leq 80$

Set left and right margins

Mode	ASCII	Decimal	Hexadecimal
IBM	<ESC> "X" n1 n2	27 88 n1 n2	1B 58 n1 n2

Sets the left margin at column *n1* and the right margin at column *n2*. See the preceding commands for margin restrictions and other notes.

Carriage return

Mode	ASCII	Decimal	Hexadecimal
Both	<CR>	13	0D

Prints the current line and returns the next print position to the left margin. If EDS switch A-4 is set to OFF, also performs a line feed.

Set automatic line feed

Mode	ASCII	Decimal	Hexadecimal
IBM	<ESC> "5" <I>	27 53 1	1B 35 01

Causes the printer to perform both a carriage return and line feed each time it receives a <CR> code. This command takes priority over EDS switch A-4.

Cancel automatic line feed

Mode	ASCII	Decimal	Hexadecimal
IBM	<ESC> "5" <O>	27 53 0	1B 35 00

Causes the printer to perform only a carriage return when it receives a <CR> code. This command takes priority over EDS switch A-4.

Backspace

Mode	ASCII	Decimal	Hexadecimal
Both	<BS>	8	08

Moves the print position one column to the left. Ignored if the print position is at the left margin. This command can be used to overstrike or combine characters.

Left justify

Mode	ASCII	Decimal	Hexadecimal
Std.	<ESC> "a" <0>	27 97 0	1B 61 00

Aligns subsequent text with the left margin, leaving the right margin ragged.

Center text

Mode	ASCII	Decimal	Hexadecimal
Std.	<ESC> "a" <1>	27 97 1	1B 61 01

Centers subsequent text between the left and right margins.

Right justify

Mode	ASCII	Decimal	Hexadecimal
Std.	<ESC> "a" <2>	27 97 2	1B 61 02

Aligns subsequent text with the right margin, leaving the left margin ragged.

Full justify

Mode	ASCII	Decimal	Hexadecimal
Std.	<ESC> "a" <3>	27 97 3	1B 61 03

Aligns subsequent text between the left and right margins.

Set horizontal tab stops

Mode	ASCII	Decimal	Hexadecimal
Both	<ESC> "D" <i>n1</i> <i>n2</i> <0>	27 68 <i>n1</i> <i>n2</i> 0	1B 44 <i>n1</i> <i>n2</i> ... 00

Cancels all current horizontal tab stops and sets new tab stops at columns *n1*, *n2*, etc. in the current character pitch (pica pitch if proportional spacing is currently selected), where *n1*, *n2*, etc. are numbers between 1 and 255. The maximum number of horizontal tab stops allowed is 32 in Standard mode and 28 in IBM mode. The tab stops must be specified in ascending order; any violation of ascending order terminates the tab stop list. Standard termination is by the <0> control code. To clear all tab stops, specify <ESC> "D" <0>.

Set horizontal tab stop every n columns

Mode	ASCII	Decimal	Hexadecimal
Std.	<ESC> "e" <0> n	27 101 0 n	1B 65 00 n

Cancels all current horizontal tab stops and sets new tab stops every n columns, where n is between 1 and 127.

Reset all tab stops

Mode	ASCII	Decimal	Hexadecimal
IBM	<ESC> "R"	27 82	1B 52

Resets the horizontal tab stops to their power-up values in which a tab stop is set every 8 column starting at column 9. Also clears all vertical tab stops.

Horizontal tab

Mode	ASCII	Decimal	Hexadecimal
Both	<HT>	9	09

Moves the print position to the next horizontal tab stop. Ignored if there is no next horizontal tab stop in the current line. Note that when underlining is selected, spaces skipped by horizontal tabulation are not underlined.

Relative horizontal tab

Mode	ASCII	Decimal	Hexadecimal
Std.	<ESC> "\ " $n1$ $n2$	27 92 $n1$ $n2$	1B 5C $n1$ $n2$

Moves the print position right or left a specified distance. Ignored if the resulting position is beyond the right or left margin. The formulas for the distance and direction are as follows:

If $n2$ is between 0 and 63, the print head moves right by $(n1 + n2 \times 256)$ dots.

If you want to move the print head to the left, $n1$ and $n2$ are obtained by subtracting the value from 65536, and dividing the result into high and low bytes.

Relative horizontal tab in inches

Mode	ASCII	Decimal	Hexadecimal
IBM	<ESC> "d" $n1$ $n2$	27 100 $n1$ $n2$	1B 64 $n1$ $n2$

Sets the next print position to $(n1 + n2 \times 256)/120$ inches from the current position. Ignored if this position is beyond the right margin.

Absolute horizontal tab in inches

Mode	ASCII	Decimal	Hexadecimal
Std.	<ESC> "\$" $n1$ $n2$	27 36 $n1$ $n2$	1B 24 $n1$ $n2$

Sets the next print position to $(n1 + n2 \times 256)/60$ inches from the left margin on the current line. Ignored if this position is beyond the right margin.

Absolute horizontal tab in columns

Mode	ASCII	Decimal	Hexadecimal
Std.	<ESC> "f" <0> n	27 102 0 n	1B 66 00 n

Moves the next print position to column n from the left margin, where n is between 0 and 127.

GRAPHICS COMMANDS

Print normal-density 8-bit graphics

Mode	ASCII	Decimal	Hexadecimal
Both	<ESC> "K" $n1$ $n2$ $m1$ $m2$...	27 75 $n1$ $n2$ $m1$ $m2$...	1B 4B $n1$ $n2$ $m1$ $m2$...

Prints bit-image graphics at 60 dots per inch horizontally. The graphic image is 8 dots high and $n1 + n2 \times 256$ dots wide. Maximum width is 8 inches (480 dots). $m1, m2, \dots$ are the dot data, each a 1-byte value from 0 to 255 representing 8 vertical dots, with the most significant bit at the top and the least significant bit at the bottom. The number of data bytes must be $n1 + n2 \times 256$. Dots beyond the right margin are ignored. At the end of bit-image printing the printer returns automatically to character mode.

Print double-density 8-bit graphics

Mode	ASCII	Decimal	Hexadecimal
Both	<ESC> "L" $n1$ $n2$ $m1$ $m2$...	27 76 $n1$ $n2$ $m1$ $m2$...	1B 4C $n1$ $n2$ $m1$ $m2$...

Prints bit-image graphics at 120 dots per inch horizontally (maximum 960 dots wide). See <ESC> "K" for other information.

Print double-density, double-speed 8-bit graphics

Mode	ASCII	Decimal	Hexadecimal
Both	<ESC> "Y" $n1$ $n2$ $m1$ $m2$...	27 89 $n1$ $n2$ $m1$ $m2$...	1B 59 $n1$ $n2$ $m1$ $m2$...

Prints bit-image graphics at 120 dots per inch horizontally (maximum 960 dots wide), skipping every second dot in the horizontal direction. See <ESC> "K" for other information.

Print quadruple-density 8-bit graphics

Mode	ASCII	Decimal	Hexadecimal
Both	<ESC> "Z" $n1$ $n2$ $m1$ $m2$...	27 90 $n1$ $n2$ $m1$ $m2$...	1B 5A $n1$ $n2$ $m1$ $m2$...

Prints bit-image graphics at 240 dots per inch horizontally (maximum 1920 dots wide), skipping every second dot in the horizontal direction. See <ESC> "K" for other information.

Print hex-density 24-bit graphics

Mode	ASCII	Decimal	Hexadecimal
Std.	<FS> "Z" $n1$ $n2$ $m1$ $m2$ $m3$...	28 90 $n1$ $n2$ $m1$ $m2$ $m3$...	1C 5A $n1$ $n2$ $m1$ $m2$ $m3$...

Prints 24-bit dot graphics at 360 dots per inch horizontally. The graphics image is 24 dots high and $n1 + n2 \times 256$ dots wide. Maximum width is 8 inches (2880 dots). In the data $m1$, $m2$, $m3$... each three bytes represent 24 vertical dots. In the leftmost position, the most significant bit of $m1$ is the top dot; the least significant bit of $m1$ is the eighth dot from the top; the most significant bit of $m2$ is the ninth dot; the least significant bit of $m2$ is the sixteenth dot from the top; the most significant bit of $m3$ is the seventeenth dot from the top; the least significant bit of $m3$ is the bottom dot. The rest of data is similar. The number of data bytes must be $3 \times (n1 + n2 \times 256)$. Dots beyond the right margin are ignored. At the end of dot graphics printing, the printer returns automatically to character mode.

Select graphics mode

Mode	ASCII	Decimal	Hexadecimal
Std.	<ESC> "*" <i>n0 n1</i> <i>n2 m1 m2 ...</i>	27 42 <i>n0 n1</i> <i>n2 m1 m2 ...</i>	1B 2A <i>n0 n1</i> <i>n2 m1 m2 ...</i>

Selects one of eleven graphics modes depending on the value of *n0* and prints bit-image graphics in this mode. See <ESC> "K" (for 8-bit graphics) or <FS> "Z" (for 24-bit graphics) for information on *n1, n2, m1, m2, ...*

n0 Graphics mode

0	8-bit Normal-density	(60 dots per inch)
1	8-bit Double-density	(120 dots per inch)
2	8-bit Double-density, double-speed	(120 dots per inch)
3	8-bit Quadruple-density	(240 dots per inch)
4	8-bit CRT graphics, mode I	(80 dots per inch)
6	8-bit CRT graphics, mode II	(90 dots per inch)
32	24-bit Normal-density	(60 dots per inch)
33	24-bit Double-density	(120 dots per inch)
38	24-bit CRT graphics	(90 dots per inch)
39	24-bit Triple-density	(180 dots per inch)
40	24-bit Hex-density	(360 dots per inch)

Select graphics mode

Mode	ASCII	Decimal	Hexadecimal
IBM	<ESC> "[" "g" <i>n1 n2</i> <i>m0 m1 m2 ...</i>	28 91 103 <i>n1 n2</i> <i>m0 m1 m2 ...</i>	1B 5B 67 <i>n1 n2</i> <i>m0 m1 m2 ...</i>

Selects one of eight graphics modes depending on the value of *m0* and prints dot graphics in this mode. The graphics image is $(n1 + n2 \times 256) - 1$ dots wide. See <ESC> "K" (for 8-bit graphics) or <FS> "Z" (for 24-bit graphics) for information on *m1, m2, ...*

m0 Graphics mode

0	8-bit Normal-density	(60 dots per inch)
1	8-bit Double-density	(120 dots per inch)
2	8-bit Double-density, double-speed	(120 dots per inch)
3	8-bit Quadruple-density	(240 dots per inch)
8	24-bit Normal-density	(60 dots per inch)
9	24-bit Double-density	(120 dots per inch)
11	24-bit Triple-density	(180 dots per inch)
12	24-bit Hex-density	(360 dots per inch)

Convert graphics density

Mode	ASCII	Decimal	Hexadecimal
Std.	<ESC> “?” <i>n m</i>	27 63 <i>n m</i>	1B 3F <i>n m</i>

Converts graphics defined by subsequent <ESC> “K”, <ESC> “L”, <ESC> “Y” or <ESC> “Z” commands to a density mode defined by <ESC> “*”. *n* is “K”, “L”, “Y” or “Z”, indicating the mode to be converted. *m* is a code from <0> to <4> or <6> indicating one of the modes of <ESC> “*”.

DOWNLOAD CHARACTER COMMANDS

Define download characters

Mode	ASCII	Decimal	Hexadecimal
Std.	<ESC> "&" <0> <i>n1</i> <i>n2</i> <i>m0</i> <i>m1</i> <i>m2</i> <i>d1</i> <i>d2</i> ... <i>dx</i>	27 38 0 <i>n1</i> <i>n2</i> <i>m0</i> <i>m1</i> <i>m2</i> <i>d1</i> <i>d2</i> ... <i>dx</i>	1B 26 00 <i>n1</i> <i>n2</i> <i>m0</i> <i>m1</i> <i>m2</i> <i>d1</i> <i>d2</i> ... <i>dx</i>

Defines one or more new characters and stores them in RAM for later use. EDS switch A-3 must be set OFF; otherwise RAM is used as an input buffer, not downloading characters, and this command is ignored.

n1 is the character code of the first character defined and *n2* is the character code of the last character defined. *n1* must be equal to or less than *n2*.

The data for each character start with three bytes specifying proportional spacing attributes: the first byte, *m0*, specifies the left of the character; the second byte, *m1*, specifies the character width; the third byte, *m2*, specifies the right of the character.

These values must not exceed the following maximum limits:

Character mode	<i>m1</i>	<i>m0</i> + <i>m1</i> + <i>m2</i>
Draft	9	12
LQ pica	31	36
LQ elite	27	30
LQ semi-condensed	21	24
LQ proportional	37	42
Draft super/subscript	7	12
LQ super/subscript	19	36
LQ prop. super/subscript	37	42

Next comes the dot data. Normal character height is 24 dots, so there must be $3 \times m1$ bytes of dot data. If the printer is in super/subscript mode, however, the character height is 16 dots, so there must be $2 \times m1$ bytes of dot data.

Each data byte indicates eight vertical dots, with the most significant bit being the top dot, and the least significant bit being the bottom dot.

Define download characters

Mode	ASCII	Decimal	Hexadecimal
IBM	<ESC> “=” $n1$ $n2$ “#” $n3$ $n4$ <0> $n5$ $m1$ $m2$... $m9$ $d1$ $d2$... dx	27 61 $n1$ $n2$ 35 $n3$ $n4$ 0 $n5$ $m1$ $m2$... $m9$ $d1$ $d2$... dx	1B 3D $n1$ $n2$ 23 $n3$ $n4$ 00 $n5$ $m1$ $m2$... $m9$ $d1$ $d2$... dx

Defines new characters and stores them in RAM for later use. EDS switch A-3 must be set OFF; otherwise RAM is used as an input buffer, not downloading characters, and this command is ignored.

Downloading characters in IBM mode requires Dot Pattern data and Character Index Table data.

Dot Pattern data controls which pins fire when printing a character. Index Table data is placed in a “lookup table” that provides information on where Dot Pattern data is stored in memory and defines certain attributes of the character.

$(n1 + n2 \times 256)$ give the number of bytes to be downloaded.

$n3$ and $n4$ indicate the low order and high order addresses in which data is to be stored.

$n3$ should be 15 and $n4$ should be 128 for this printer.

$n5$ determines the character mode to be downloaded, as shown below:

$n5$	Character mode	Character width
0	Draft	10
1	LQ pica	36
2	LQ proportional	18 ~ 42
3	LQ elite	30

$m1$ through $m9$ indicate Index Table data.

$m1$ and $m2$ indicate the address where Dot Pattern is stored. $m1$ is the high-order byte. $m3$ indicates the number of columns in the character memory, and $m4$ indicates the number of columns in the character less 1.

$m5$ through $m9$ are compression mask bits. Data compression allows the efficient use of memory in storing downloaded characters providing space for more characters than would be available without compression. The printer repeats the previous dot column in the current column when the current column compression mask bit is set to 1.

It is necessary to define all of Index Table data before the Dot Pattern data to download many characters.

$d1, d2, \dots dx$ is the Dot Pattern data being downloaded.

Each data byte indicates eight vertical dots, with the most significant bit being the top dot, and the least significant bit being the bottom dot.

Copy character set from ROM into RAM

Mode	ASCII	Decimal	Hexadecimal
Std.	<ESC> ":", <0> n <0>	27 58 0 n 0	1B 3A 00 n 00

Copies the selected character set with n , as shown below, to the corresponding download character RAM area, overwriting any download data already present. Ignored when EDS switch A-3 is set ON.

n Font	n Font
0 Roman	11 Blippo (Option)
1 Sanserif	12 H-Gothic (Option)
2 Courier	13 Orane (Option)
3 Prestige	14 Cinema (Option)
4 Script	15 CODE 39 (Option)
5 OCR-B (Option)	16 UPC/EAN (Option)
6 OCR-A (Option)	17 Old Style (Option)
7 Orator (Option)	18 Firenze (Option)
8 Orator 2 (Option)	32 SLQ Roman (Option)
9 TW-Light (Option)	33 SLQ TW-Light (Option)
10 Letter Gothic (Option)	34 SLQ Script (Option)

Select download character set

Mode	ASCII	Decimal	Hexadecimal
Std.	<ESC> “%” <1>	27 37 1	1B 25 01

Selects the download character set. Ignored when EDS switch A-3 is set ON.

Shift download character area

Mode	ASCII	Decimal	Hexadecimal
Std.	<ESC> “t” <2>	27 116 2	1B 74 02
	<FS> “I” <2>	28 73 2	1C 49 02

Shifts the download character area defined between 0 to 127 to the area between 128 to 255.

Select ROM character set

Mode	ASCII	Decimal	Hexadecimal
Std.	<ESC> “%” <0>	27 58 0	1B 25 00

Stops using the download character set and returns to the built-in ROM character set. Ignored when EDS switch A-3 is set ON.

OTHER PRINTER COMMANDS

Set MSB to 1

Mode	ASCII	Decimal	Hexadecimal
Std.	<ESC> “=”	27 62	1B 3E

Sets the most significant bit of each subsequent byte received to 1, allowing users with a 7-bit interface to access characters with ASCII codes greater than 127.

Set MSB to 0

Mode	ASCII	Decimal	Hexadecimal
Std.	<ESC> “=”	27 61	1B 3D

Sets the most significant bit of each subsequent byte received to 0.

Accept MSB as is

Mode	ASCII	Decimal	Hexadecimal
Std.	<ESC> “#”	27 35	1B 23

Cancels the preceding commands and accepts the most significant bit as it is sent to the printer.

Delete last character sent

Mode	ASCII	Decimal	Hexadecimal
Std.		127	7F

Deletes the last character received. Ignored if the last character received has already been printed, or if the last character received was all or part of a command.

Cancel last line

Mode	ASCII	Decimal	Hexadecimal
Both	<CAN>	24	18

Deletes the last line currently present in the print buffer.

Set printer off-line

Mode	ASCII	Decimal	Hexadecimal
Std.	<DC3>	19	13
IBM	<ESC> "Q" <i>n</i>	27 81 <i>n</i>	1B 51 <i>n</i>

Sets the printer off-line. The printer disregards all subsequent characters and commands except <DC1>, which returns it to the on-line. The printer's ON LINE indicator does not go off.

In the IBM mode, the value of *n* should be 36, 81, or 180.

Set printer on-line

Mode	ASCII	Decimal	Hexadecimal
Both	<DC1>	17	11

Returns the printer on-line state, allowing it to receive and process all subsequent characters and commands. This command is ignored if the printer was set off-line by pressing the ON LINE button on the control panel.

Stop printing

Mode	ASCII	Decimal	Hexadecimal
IBM	<ESC> "j"	27 106	1B 6A

Prints the entire contents of the input buffer, then sets the printer off-line. The ON LINE indicator on the control panel goes off.

Bell

Mode	ASCII	Decimal	Hexadecimal
Both	<BEL>	7	07

Sounds a brief beep tone from the printer.

Bi-directional printing

Mode	ASCII	Decimal	Hexadecimal
Both	<ESC> "U" <0>	27 85 0	1B 55 00

Causes subsequent printing to be done in the normal bi-directional mode, which is faster than uni-directional printing.

Uni-directional printing

Mode	ASCII	Decimal	Hexadecimal
Both	<ESC> "U" <I>	27 85 1	1B 55 01

Causes subsequent printing to be done uni-directionally, ensuring maximum vertical alignment precision.

One-line uni-directional printing

Mode	ASCII	Decimal	Hexadecimal
Std.	<ESC> "<"	27 60	1B 3C

Immediately returns the print head to the left margin, then prints the remainder of the line from left to right. Normal printing resumes on the next line.

Manual feed

Mode	ASCII	Decimal	Hexadecimal
Both	<ESC> <0>	27 25 0	1B 19 00

Selects manual sheet feeding even when the optional automatic sheet feeder is mounted. Ignored if EDS switch A-5 is set ON.

Auto feed

Mode	ASCII	Decimal	Hexadecimal
Both	<ESC> <4>	27 25 4	1B 19 04

Selects the automatic sheet feeder. Ignored if EDS switch A-5 is ON.

Eject paper from ASF

Mode	ASCII	Decimal	Hexadecimal
Both	<ESC> "R"	27 25 82	1B 19 52

Ejects the current page. Ignored if EDS switch A-5 is ON.

Set print start position on ASF

Mode	ASCII	Decimal	Hexadecimal
Both	<ESC> "T" <i>n</i>	27 25 84 <i>n</i>	1B 19 54 <i>n</i>

Skips $n/6$ inches at the top of the page, where n is equal to or greater than 1. Ignored if EDS switch A-5 is ON.

Reset printer

Mode	ASCII	Decimal	Hexadecimal
Both	<ESC> "@"	27 64	1B 40
Std.	<FS> "@"	28 64	1C 40

Reinitializes the printer. Clears the print buffer and returns settings to their power-up values. Does not clear the input buffer or change ASF selections.

Set initial conditions

Mode	ASCII	Decimal	Hexadecimal
IBM	<ESC> "[" "K" <3> <0> <0> <i>n1 n2</i>	27 91 75 3 0 0 <i>n1 n2</i>	1B 5B 4B 03 00 00 <i>n1 n2</i>

Reinitializes the printer to the initial conditions determined by the value of $n2$.

The value of $n2$ is the sum of the values given below for the desired characteristics.

Function	<i>n</i> value
Disable alarm	32
Auto CR with LF	16
Auto LF with CR	8
12-inch forms	4
Slashed zero	2
Character set #2	1

The value of $n1$ should be 3, 22, 35, 36, or 177.

Chapter 9

DOWNLOAD CHARACTERS

With this printer you can create new characters and symbols, download their dot data, and have them printed in place of selected characters in the regular character set. Characters that can be generated in this way range from simple but useful symbols like the check mark through to complex Chinese or Japanese characters.

Regular characters are permanently stored in the printer's ROM, but characters you design are downloaded and stored in RAM for use.

Before you start to define your own characters, you must set the EDS switch A-3 to the OFF position. Otherwise, the RAM is used to store the input buffer, and the download commands are ignored.

DEFINING YOUR OWN CHARACTERS WITH STANDARD MODE

Designing and printing your own characters has two requirements: first, designing the shape of the character, calculating the data necessary to make the shape, and sending that data to the printer, and secondly, sending the command to print the downloaded characters instead of the regular characters. There are a number of design constraints for download characters:

- The matrix or grid on which you design the characters depends upon the print mode as shown below:

Character mode	Horizontal	Vertical
Draft characters	9	24
LQ pica characters	31	24
LQ elite characters	27	24
LQ semi-condensed	19	16
LQ proportional	37	24
Draft super/subscript	7	16
LQ super/subscript	19	16
LQ prop. super/subscript	37	16

- The minimum width of a character is five dots.
- Dots cannot overlap.
- You may define any position in the ASCII table.

Photocopy the grid in Figure 9-1 to help design your new characters. We will use a tiny representation of a telephone symbol for our example.

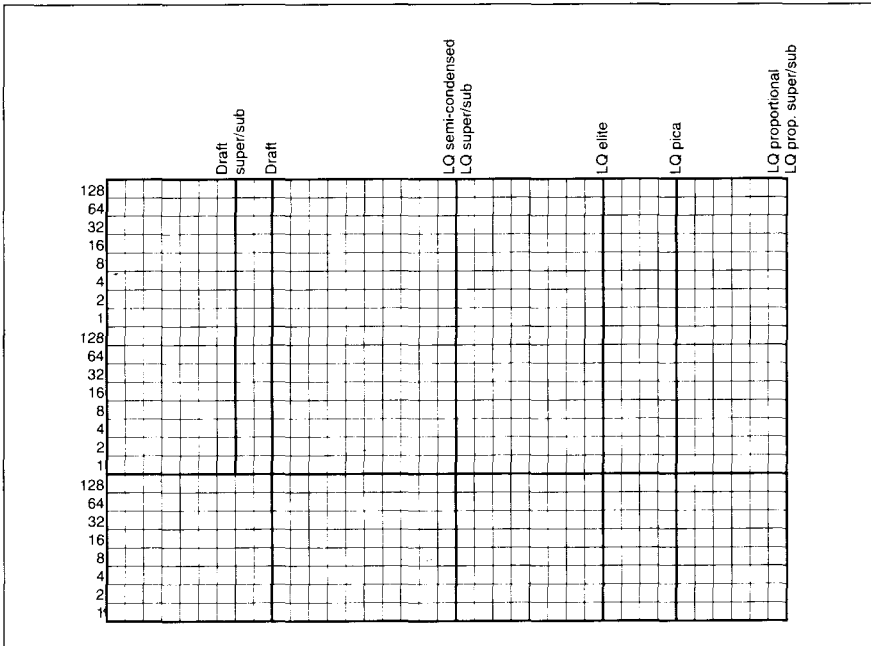

Figure 9-1. Use this grid (or one similar to it) to define your own characters.

Assigning the character data

Now, we calculate the vertical numerical values of the columns of dots, and enter them underneath the grid. Each vertical column (which has a maximum of 24 dots) is first divided into three groups (or two groups for super/subscripts) of eight dots. Each group of eight dots is represented by one byte, which consists of eight bits.

This is where the numbers down the left side of the grid come in. Notice that there is a number for each row of dots and that each number is twice the number below it. By making these numbers powers of two we can take any combination of dots in a vertical column and assign them a unique value.

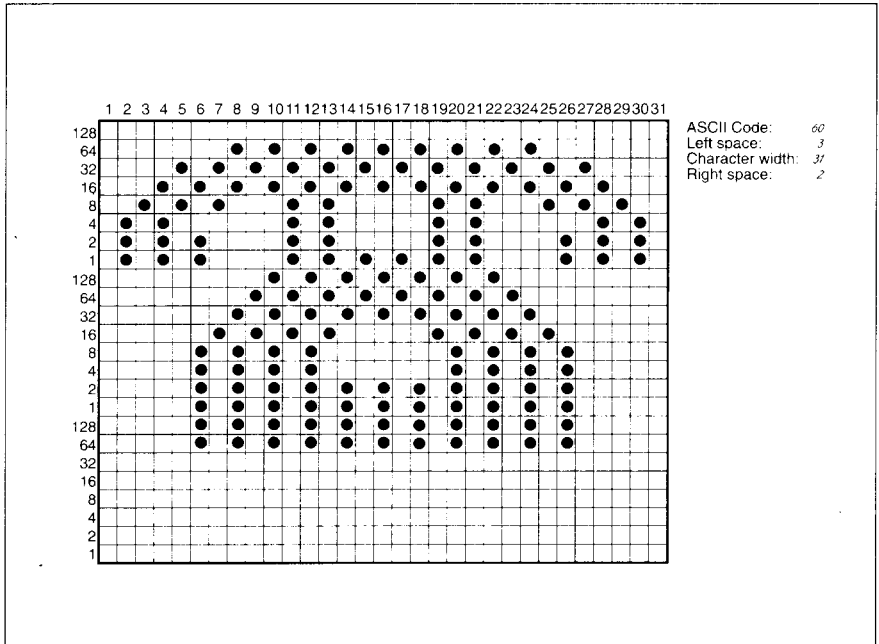

Figure 9-2. Telephone symbol with normal LQ pica.

Assigning a value of character space

Besides being able to specify the actual width of the character, this printer allows you to specify the position in the standard grid where the character will print. You must specify the dot column in which the printed character starts and the dot column in which the character ends. Why, you may ask, would you want to define a character this way instead of merely defining the overall width of the character? Because this printer's proportional character definitions can also be used to print normal width characters, and by centering even the narrow characters in the complete grid they will look good even if you are not printing them proportionately.

The three bytes are used to specify the width of the character and the space to be allowed on either side of it. The left space (in dot columns) is specified by *m0* and the right space is specified by *m2*. The second byte (*m1*) specifies the width of the character in dots. By varying the width of the character itself and the spaces around it, you can actually create proportional width characters.

When defining characters, the number of printed columns ($m1$), and the sum of side spaces and the character width ($m0 + m1 + m2$) cannot exceed the value shown below.

Character mode	$m1$	$m0 + m1 + m2$
Draft characters	9	12
LQ pica characters	31	36
LQ elite characters	27	30
LQ semi-condensed	19	24
LQ proportional	37	42
Draft super/subscript	7	12
LQ super/subscript	19	36
LQ prop. super/subscript	37	42

Sample program

To demonstrate how to use the download characters, let's use the "telephone" character and the other user-defined characters to print a small graph. This program will do just that:

```

1000 WIDTH "LPT1:",255
1010 LPRINT CHR$(27);"x1";
1020 LPRINT CHR$(27);"&";CHR$(0);
1030 LPRINT CHR$(60);CHR$(61);
1040 FOR N=60 TO 61
1050 READ LS :LPRINT CHR$(LS);
1060 READ CW :LPRINT CHR$(CW);
1070 READ RS :LPRINT CHR$(RS);
1080 FOR M=1 TO CW*3
1090 READ MM
1100 LPRINT CHR$(MM);
1110 NEXT M
1120 NEXT N
1130 LPRINT CHR$(27);"D";CHR$(11);CHR$(0)
1140 LPRINT CHR$(27);"k";CHR$(4);
1150 LPRINT CHR$(27);"h";CHR$(1);
1160 LPRINT "    DIFFUSION RANGES OF"
1170 LPRINT "    CARS & TELEPHONES"
1180 LPRINT CHR$(27);"h";CHR$(0)
1190 LPRINT CHR$(27);"k";CHR$(0);
1200 LPRINT CHR$(27);"%" ;CHR$(1);
1210 LPRINT "USA";CHR$(9);
1220 FOR I=0 TO 681 STEP 25 :LPRINT CHR$(60); :NEXT I
1230 LPRINT
1240 LPRINT CHR$(9);
1250 FOR I=0 TO 781 STEP 25 :LPRINT CHR$(61); :NEXT I
1260 LPRINT
1270 LPRINT "GERMANY";CHR$(9);
1280 FOR I=0 TO 412 STEP 25 :LPRINT CHR$(60); :NEXT I
1290 LPRINT
1300 LPRINT CHR$(9);
1310 FOR I=0 TO 488 STEP 25 :LPRINT CHR$(61); :NEXT I
1320 LPRINT
1330 LPRINT "JAPAN";CHR$(9);

```

```

1340 FOR I=0 TO 347 STEP 25 :LPRINT CHR$(60); :NEXT I
1350 LPRINT
1360 LPRINT CHR$(9);
1370 FOR I=0 TO 493 STEP 25 :LPRINT CHR$(61); :NEXT I
1380 LPRINT
1390 LPRINT CHR$(9);"+-";
1400 SCALE$="+-+-"
1410 FOR I=2 TO 8 :LPRINT SCALE$; :NEXT I
1420 LPRINT "+-+"
1430 LPRINT CHR$(9);"0 ";
1440 FOR I=1 TO 8
1450 LPRINT " ";I;
1460 NEXT I
1470 LPRINT CHR$(27);"%";CHR$(0)
1480 LPRINT CHR$(27);"M";
1490 LPRINT CHR$(27);"S";CHR$(0);
1500 LPRINT CHR$(9);"(100 UNITS/1000 PERSONS)"
1510 LPRINT CHR$(27);"T";
1520 LPRINT CHR$(27);"@";
1530 END
2000 ' DATA
2010 ' Telephone Symbol
2020 DATA 3, 31, 2
2030 DATA 0, 0, 0, 7, 0, 0, 8, 0, 0, 23, 0, 0, 40, 0, 0
2040 DATA 19, 15,192, 40, 16, 0, 80, 47,192, 32, 80, 0, 80,175,192
2050 DATA 47, 80, 0, 80,175,192, 47, 80, 0, 80,163,192, 33, 64, 0
2060 DATA 80,163,192, 33, 64, 0, 80,163,192, 47, 80, 0, 80,175,192
2070 DATA 47, 80, 0, 80,175,192, 32, 80, 0, 80, 47,192, 40, 16, 0
2080 DATA 19, 15,192, 40, 0, 0, 23, 0, 0, 8, 0, 0, 7, 0, 0
2090 DATA 0, 0, 0
2100 ' Car Symbol
2110 DATA 3, 31, 2
2120 DATA 0, 0, 0, 0, 30, 0, 0, 0, 0, 0, 60, 0, 0, 3, 0
2130 DATA 0,252,128, 0, 3, 64, 1,252,128, 2, 3, 64, 5,124,128
2140 DATA 10, 3, 0, 20,124, 0, 40, 0, 0, 80,126, 0, 32, 0, 0
2150 DATA 64,126, 0, 63,128, 0, 64,126, 0, 63,128, 0, 64,124, 0
2160 DATA 32, 3, 0, 64,124,128, 32, 3, 64, 64,124,128, 48, 3, 64
2170 DATA 76,124,128, 51, 3, 0, 12,252, 0, 3, 0, 0, 0,254, 0
2180 DATA 0, 0, 0

```

DIFFUSION RANGES OF CARS & TELEPHONES

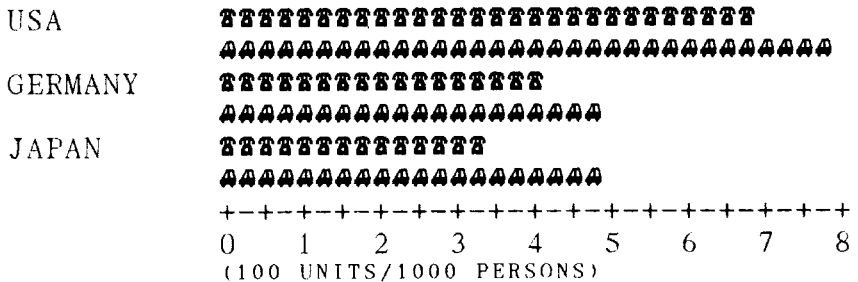

DEFINING YOUR OWN CHARACTERS WITH IBM MODE

Downloading fonts in IBM mode requires downloading character Dot Pattern data and character Index Table data. Dot pattern data controls which pins fire when printing a character. Index Table data is placed in a “lookup table” that provides information on where Dot Pattern data is stored in memory and defines certain attributes of the character.

Assigning the download character set

You can define one or more download character sets for later use in IBM mode. Before you start to design your characters, you must define what character set(s) you want to download.

The character width on which you design the characters depends upon the character set as shown below:

Character set	Character width	Character ID
Draft characters	9	0
LQ pica characters	35	1
LQ elite characters	29	2
LQ proportional	17 ~ 41	3

After you have decided your download character set, you must tell the printer where the download character data to be stored, and how many download character sets you will define.

The first download font area starts from <800F>h, and you must enter 0 for the Format byte. This Format byte indicates to the printer that the RAM is stored the download character set.

Following the format byte, you must enter the Character ID data. If you want to define more character set, add 128 to the Character ID data.

The second area starts from <8911>h, the third area starts from <9212>h, and the last area starts from <9B13>h. But you need not enter the Format byte for these area.

Assigning the character dot pattern

We will use a tiny representation of a telephone symbol for our example.

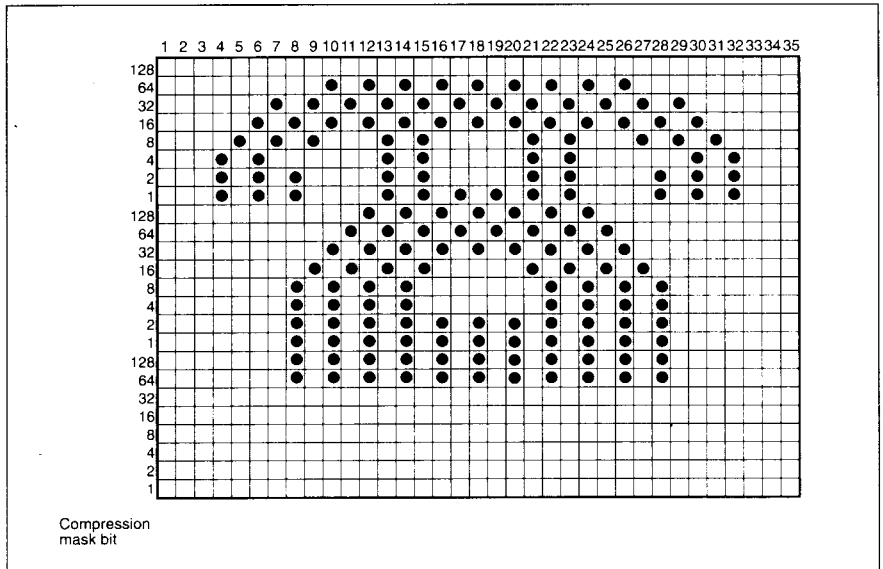

Figure 9-3. Telephone symbol with LQ pica.

After you have designed the character pattern, you will need to compress the Dot Pattern. Data compression allows you to store more download characters than without compression. It is a more efficient use of memory. The printer will repeat the previous dot column when the current column compression mask bit is set to “1”.

Fill up the adjacent dot even they do not print, then compare the each vertical line to the left line. If the line is the same as the left one, write “1” in the column of the “compression mask bit”. If it is different, write “0”.

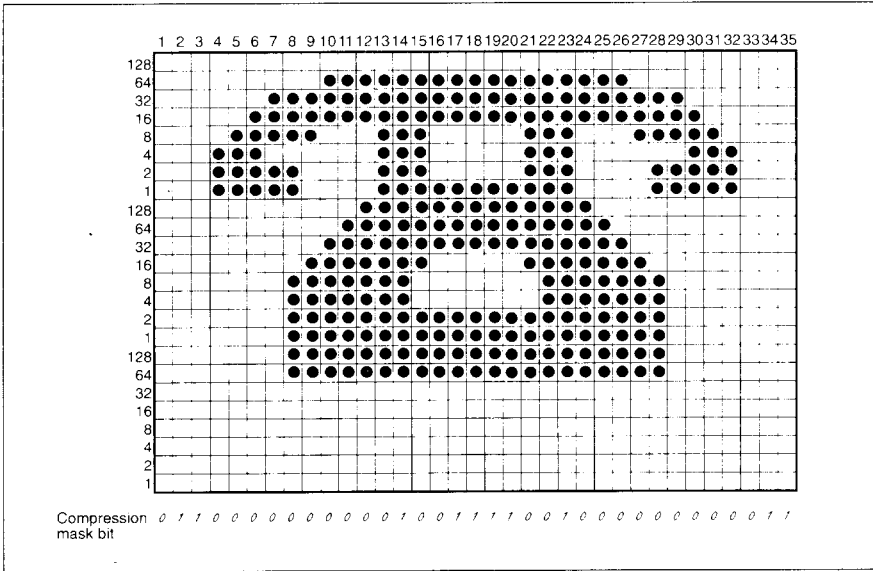

Figure 9-4. Fill up the adjacent dot, then write the "compression data".

After you have written the "compression mask bit" data, line up all the character data for the "compression mask bit" that requires "0". The telephone symbol looks like Figure 9-5.

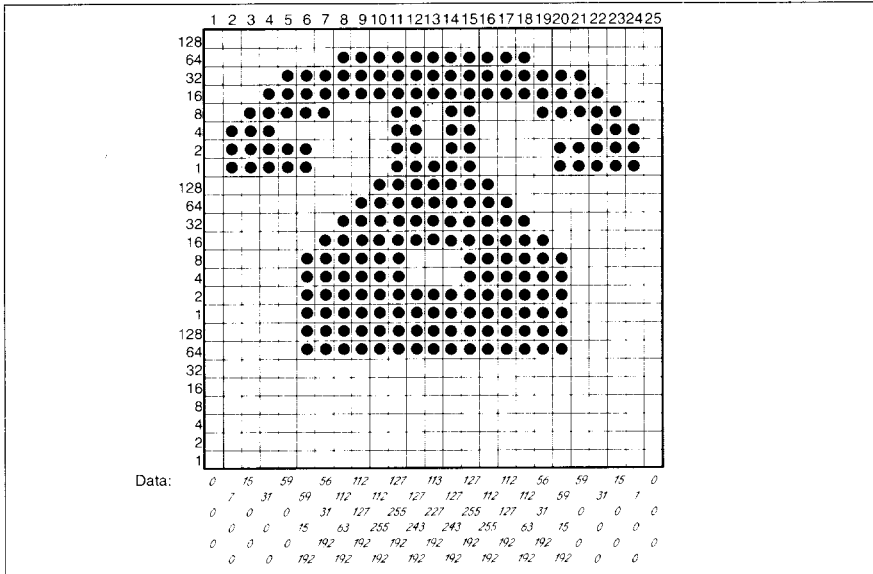

Figure 9-5. Compressed character pattern of telephone symbol.

Now we will calculate the vertical numerical values of the columns of dots, and enter them underneath the grid. Each vertical column is first divided into three groups of eight dots. Each group of eight dots is represented by one byte, which consists of eight bits.

This is where the numbers down the left side of the grid come in. Notice that there is a number for each row of dots and that each number is twice the number below it. By making these numbers powers of two we can take any combination of dots in a vertical column and assign them a unique value.

Assigning the Index Table data

Unlike defining in the Standard mode, you must assign the Index Table with the IBM mode. This Index Table is prepared for the information of each character's attribute data, such as character type (Normal 24-dot high, or 30-dot high block graphics), the dot pattern data in the memory, and the compression mask bit data.

Each character requires 9 index table data.

The first and the second bytes ($m1$ and $m2$) indicate the position of the first dot pattern in the memory. $m1$ is the high order byte, and $m2$ is the low order byte.

The third byte, $m3$, indicates the character type and the dot pattern data width in the memory.

If the character is normal, simply enter the width of dot pattern in the memory. If the character is a block graphic, add 128 to the width of dot pattern in the memory.

Our telephone symbol is a normal character and the width of the dot pattern in the memory should be 25, so this value is 25.

The fourth byte, $m4$, indicates the printing attribute.

This byte indicates the character width to be printed, and information of the repetition dots for block graphics characters.

If the character is a normal character, add 192 to the character width.

If the character is a block character, and it should be printed as a line draw character, add 64 to the character width. If the block character is not a line draw character, this byte should be the same as the character width.

Our telephone symbol is a normal pica character, so the character width is 35, and this byte should be 227.

The remaining five bytes (*m5* through *m9*) indicate the compression mask bits. Each bits shows the data that will translate the compressed dot pattern data back to the original character pattern.

For example, the compression mask bits of our telephone symbol are 01100000 00000100 11110010 00000000 01100000. So these bytes are 96, 4, 242, 0, and 96.

You must define the index table data for all characters from 0 to 255. If you do not want to define a particular character, enter 0 into that index table data.

Sample program

To demonstrate how to define and to use the download characters in IBM mode, let's use the "telephone" character and the other user-defined characters to print a small graph. This program will do just that:

```
1000 WIDTH "LPT1:",255
1010 LPRINT CHR$(27);"=";CHR$(164);CHR$(9);"#";
1020 LPRINT CHR$(&HOF);CHR$(&H80);CHR$(0);
1030 ' INDEX TABLE
1040 LPRINT CHR$(1);
1050 FOR I=0 TO 59
1060 LPRINT STRING$(9,0);
1070 NEXT I
1080 FOR IT=1 TO 9 :READ MM :LPRINT CHR$(MM); :NEXT IT
1090 FOR IT=1 TO 9 :READ MM :LPRINT CHR$(MM); :NEXT IT
1100 FOR I=62 TO 255
1110 LPRINT STRING$(9,0);
1120 NEXT I
1130 ' DOT PATTERN
1140 FOR DP=1 TO 159
1150 READ MM
1160 LPRINT CHR$(MM);
1170 NEXT DP
1180 ' PRINTOUT PROGRAM
1190 LPRINT CHR$(27);"D";CHR$(11);CHR$(0)
1200 LPRINT CHR$(27);"k";CHR$(4);
1210 LPRINT CHR$(27);"h";CHR$(1);
1220 LPRINT "    DIFFUSION RANGES OF"
1230 LPRINT "    CARS & TELEPHONES"
1240 LPRINT CHR$(27);"h";CHR$(0);
1250 LPRINT CHR$(27);"k";CHR$(0)
1260 LPRINT "USA";CHR$(9);
1270 LPRINT CHR$(27);"I";CHR$(6);
1280 FOR I=0 TO 681 STEP 25 :LPRINT CHR$(60); :NEXT I
1290 LPRINT
1300 LPRINT CHR$(9);
1310 FOR I=0 TO 781 STEP 25 :LPRINT CHR$(61); :NEXT I
1320 LPRINT CHR$(27);"I";CHR$(2)
1330 LPRINT "GERMANY";CHR$(9);
1340 LPRINT CHR$(27);"I";CHR$(6);
1350 FOR I=0 TO 412 STEP 25 :LPRINT CHR$(60); :NEXT I
1360 LPRINT
1370 LPRINT CHR$(9);
1380 FOR I=0 TO 488 STEP 25 :LPRINT CHR$(61); :NEXT I
1390 LPRINT CHR$(27);"I";CHR$(2)
1400 LPRINT "JAPAN";CHR$(9);
```

```

1410 LPRINT CHR$(27);"I";CHR$(6);
1420 FOR I=0 TO 347 STEP 25 :LPRINT CHR$(60); :NEXT I
1430 LPRINT
1440 LPRINT CHR$(9);
1450 FOR I=0 TO 493 STEP 25 :LPRINT CHR$(61); :NEXT I
1460 LPRINT CHR$(27);"I";CHR$(2)
1470 LPRINT CHR$(9);"+-";
1480 SCALE$="+-+--"
1490 FOR I=0 TO 2 :LPRINT SCALE$; :NEXT I
1500 LPRINT "+-+"
1510 LPRINT CHR$(9);"0 ";
1520 FOR I=1 TO 8
1530 LPRINT " ";I;
1540 NEXT I
1550 LPRINT CHR$(27);": ";
1560 LPRINT CHR$(27);"S";CHR$(0);
1570 LPRINT CHR$(9);"(100 UNITS/1000 PERSONS)"
1580 LPRINT CHR$(27);"T";
1590 LPRINT CHR$(27);"@"
1600 END
2000 ' DATA
2010 ' Index Table Data
2020 DATA 137, 17, 25,227, 96, 4,242, 0, 96
2030 DATA 137, 92, 28,227, 96, 0, 80, 64, 96
2040 ' Dot Pattern Data
2050 ' Telephone symbol
2060 DATA 0, 0, 0, 7, 0, 0, 15, 0, 0, 31, 0, 0, 59, 0, 0
2070 DATA 59, 15,192, 56, 31,192,112, 63,192,112,127,192,112,255,192
2080 DATA 127,255,192,127,243,192,113,227,192,127,243,192,127,255,192
2090 DATA 112,255,192,112,127,192,112, 63,192, 56, 31,192, 59, 15,192
2100 DATA 59, 0, 0, 31, 0, 0, 15, 0, 0, 7, 0, 0, 0, 0, 0
2110 ' Car symbol
2120 DATA 0, 0, 0, 0, 30, 0, 0, 28, 0, 0, 60, 0, 0, 63, 0
2130 DATA 0,255,128, 0,255,192, 1,255,192, 3,255,192, 7,127,128
2140 DATA 14,127, 0, 28,124, 0, 56,124, 0,112,126, 0, 96,124, 0
2150 DATA 127,254, 0,127,252, 0, 96,124, 0, 96,127, 0, 96,127,128
2160 DATA 96,127,192,112,127,192,124,127,128, 63,127, 0, 15,124, 0
2170 DATA 3,124, 0, 0,254, 0, 0, 0, 0

```

MEMO

Chapter 10

MS-DOS AND YOUR PRINTER

When using your printer with an IBM PS/2, PC-AT or compatible, you will probably be using PC-DOS or MS-DOS as an operating system. A number of software tricks may be useful here. This chapter is not, however, a substitute for the operating system manuals supplied with your computer.

To learn how to print files, etc. it is best to read the relevant parts of these manuals.

PROGRAMMING THE PRINTER WITH DOS COMMANDS

If your system includes the file PRINT.COM you can use the main DOS printing command. Simply type the word PRINT followed by the name of the file you want to print. To print a file named README.DOC, for example, type:

```
A>PRINT README.DOC
```

The computer may respond with the following message, asking which printer to use:

```
Name of list device [PRN]:
```

If your computer is connected to only one printer, press RETURN to select the default choice (PRN). Printing will begin and the A> prompt will reappear. You can execute other commands or programs while the file is being printed.

A single PRINT command can print two or more files. List the file names consecutively on the same line, or use wild-card characters (* and ?). Each file will be printed starting on a new page. The PRINT command also has control options. For example, you can terminate a printing job in progress with the /T option. (The printer may not stop printing immediately as there may be considerable data stored ahead in its buffer.) For the /T option, type:

```
A>PRINT/T
```

See your DOS manual for further information about the PRINT command. If your system does not include PRINT.COM, you can print files by using the PRN device name in COPY or TYPE commands such as the following:

```
A>COPY README.DOC PRN
A>TYPE README.DOC >PRN
```

COPY and TYPE do not permit you to execute other commands while the file is printing.

If you want a particular font, or print pitch, you can make these settings from the control panel before you start printing. See Chapter 4.

If you print from the DOS command level very often, it will be advantageous to create a printer setup file. Then instead of setting font etc. manually each time, you can complete the setup with a single command from your computer. For example, you can create a file containing printer commands to select letter quality, and select elite pitch with the Standard mode. You can find the commands in Chapter 8. We suggest the following:

- Letter quality <ESC> "x" "1"
- Elite pitch <ESC> "!" <1>

<ESC> "!" <1> is a powerful command that, in addition to selecting elite pitch, cancels unwanted features such as underlining which might be left from previous commands. The angle brackets around the <1> indicate character code 1, which is a control code, not the printable digit "1".

You may want to place additional commands in this file, such as left and right margins, line spacing and bottom margin commands. Or you may want to create a variety of setup files with a different set of commands in each.

To avoid excess line feeds, you should place the commands on one line in the setup file. You may or may not be able to generate a setup file with word-processing software; it depends on whether your software lets you enter control codes. If your system includes the file EDLIN.COM, however, you can easily create a setup file with the DOS line editor.

An appropriate name for this setup file would be LQELITE.DAT. To use the DOS line editor, type the command EDLIN LQELITE.DAT, then type the underlined parts of the following display. Press RETURN at the end of each line. Do not type the symbol "^". This symbol means to hold the CTRL key down while pressing the next key: for example, ^V means to type CTRL-V. ^C means to type CTRL-C, which indicates the end of the input.

```

A>EDLIN LQELITE.DAT
New file
*1
      1: *^V[x1^V[!^VA
      2: *^C
*E

```

^V indicates that the following character is a control code. ^V[enters the <ESC> code. <ESC> has character code 27, and “[” is the 27th character from A in the ASCII sequence. Similarly, ^VA enters the control code <I>. See your DOS manual if you need further information about EDLIN.

You can now set up the printer by sending it the file LQELITE.DAT. To avoid unnecessary logging of commands, switch hard-copy output off (by pressing CTRL-PRTSC if hard copy is on). To print the file README.DOC in LQ elite type, give the following two commands:

```

A>COPY LQELITE.DAT PRN
A>PRINT README.DOC

```

For greater convenience you can make a batch file that will set up the printer and print any specified file with a single command. To create such a batch file with the name LQPRINT.BAT, type in the first four lines shown next. ^Z means to press the CTRL and Z keys simultaneously. To use this file to print README.DOC, type the fifth line.

```

A>COPY CON LQPRINT.BAT
COPY LQELITE.DAT PRN
PRINT %1
^Z
A>LQPRINT README.DOC

```

The first line above is a copy command from the CONsole screen to a file named LQPRINT.BAT. The next two lines are the contents of this file. The %1 is a dummy parameter: whatever file name you type after LQPRINT will be substituted for %1 and printed.

PROGRAMMING WITH BASIC

As an example of programming the printer on Microsoft BASIC, we have listed the program for the IBM-PC. This program runs in the printer's Standard mode, and the downloadable condition.

```
1000 ' Set control codes
1010 E$=CHR$(27) 'Escape code
1020 D$=E$+"x0" 'Draft quality
1030 L$=E$+"x1"+E$+"k" 'Letter quality
1040 R$=L$+CHR$(0) 'Roman character
1050 H$=CHR$(9) 'Horizontal tab
1060 P$=E$+"P" 'Pica pitch
1070 ' Start printing
1080 WIDTH "LPT1:",255
1090 LPRINT E$:"D";CHR$(3);CHR$(24);CHR$(0) 'Set HT
1100 LPRINT L$:CHR$(0);"Resident LQ fonts are:"
1110 LPRINT H$:L$:CHR$(0);"Roman characters,":
1120 LPRINT H$:L$:CHR$(1);"Sanserif characters,":
1130 LPRINT H$:L$:CHR$(2);"Courier characters,":
1140 LPRINT H$:L$:CHR$(3);"Prestige characters,":
1150 LPRINT H$:L$:CHR$(4);"Script characters."
1160 LPRINT
1170 LPRINT R$:"Print pitches are:"
1180 LPRINT H$:P$;"Pica pitch (10 CPI).":
1190 LPRINT H$:E$:"M":"Elite pitch (12 CPI).":
1200 LPRINT H$:E$:"g":"Semi-condensed pitch (15 CPI).":
1210 LPRINT H$:P$:
1220 LPRINT CHR$(15); 'Select condensed print
1230 LPRINT "Condensed pica pitch (17 CPI).":
1240 LPRINT H$:E$:"M":"Condensed elite pitch (20 CPI).":
1250 LPRINT CHR$(18) 'Cancel condensed print
1260 LPRINT H$:E$:"p1": 'Select proportional spacing
1270 LPRINT P$:"Normal proportional,":
1280 LPRINT H$:CHR$(15);"Condensed proportional.":
1290 LPRINT CHR$(18):
1300 LPRINT E$:"p0" 'Cancel proportional spacing
1310 LPRINT
1320 LPRINT H$:E$:"w1":"Double-height,":E$:"w0"
1330 LPRINT H$:E$:"W1":"Double width, ";E$:"W0"
1340 LPRINT H$:CHR$(28);"E";CHR$(2);"Triple width.":
1350 LPRINT CHR$(28);"E";CHR$(0)
1360 LPRINT H$:E$:"h";CHR$(1);"Double-sized,":
1370 LPRINT H$:E$:"h";CHR$(2);"Quad-sized.":
1380 LPRINT E$:"h";CHR$(0)
1390 LPRINT :LPRINT
1400 LPRINT E$:"Q";CHR$(47) 'Set right margin
1410 LPRINT T$:"Various line and character spacings:"
1420 LPRINT E$:"a1" 'Center text
1430 FOR I=1 TO 7
1440 LPRINT E$:"A";CHR$(I); 'Line spacing set
1450 LPRINT E$:" ";CHR$(I); 'Increase character space
1460 LPRINT "THE SPACINGS ARE CHANGED"
1470 NEXT I
1480 FOR I=7 TO 1 STEP -1
1490 LPRINT E$:"A";CHR$(I); 'Line spacing set
1500 LPRINT E$:" ";CHR$(I); 'Increase character space
1510 LPRINT "THE SPACINGS ARE CHANGED"
1520 NEXT I
1530 LPRINT E$:"a0" 'Left justify
1540 LPRINT E$:"3";CHR$(30); 'Set 1/6" line spacing
1550 LPRINT E$:" ";CHR$(0); 'Normal character space
1560 LPRINT :LPRINT
1570 LPRINT R$;"Other features:"
```



```

1580 LPRINT H$;E$;"q";CHR$(1);"OUTLINED";E$;"q";CHR$(0);", " ;
1590 LPRINT E$;"q";CHR$(2);"SHADOWED";E$;"q";CHR$(0);", " ;
1600 LPRINT E$;"q";CHR$(3);"OUTLINED WITH SHADOWED";
1610 LPRINT E$;"q";CHR$(0);", "
1620 LPRINT H$;E$;"E";"Emphasized";E$;"F";", " ;
1630 LPRINT E$;"G";"Double-strike";E$;"H";", " ;
1640 LPRINT E$;"4";"Italics";E$;"5";", "
1650 LPRINT H$;E$;"-1";"Underlining";E$;"-0";", " ;
1660 LPRINT E$;"(-";CHR$(3);CHR$(0);CHR$(1);CHR$(2);CHR$(2);
1670 LPRINT "Strike-through";
1680 LPRINT E$;"(-";CHR$(3);CHR$(0);CHR$(1);CHR$(2);CHR$(0);", " ;
1690 LPRINT E$;"(-";CHR$(3);CHR$(0);CHR$(1);CHR$(3);CHR$(1);
1700 LPRINT "Overlining";
1710 LPRINT E$;"(-";CHR$(3);CHR$(0);CHR$(1);CHR$(3);CHR$(0);", "
1720 LPRINT H$;E$;"S0";"SUPERSCRIPT";E$;"T";" and ";
1730 LPRINT E$;"S1";"SUBSCRIPT";E$;"T";", "
1740 LPRINT H$;RM$;"Download characters: " ;
1750 SS$=E$+"S0" 'Superscript
1760 GOSUB 2520
1770 LPRINT E$;"%1"; 'Select download character
1780 FOR I=1 TO 5
1790 LPRINT CHR$(60); 'Print download character
1800 NEXT I
1810 LPRINT E$;"%0"; 'Select normal character
1820 LPRINT E$;"T"; 'Cancel superscript
1830 GOSUB 2650
1840 LPRINT E$;"%1"; 'Select download character
1850 FOR I=1 TO 5
1860 LPRINT CHR$(60); 'Print download character
1870 NEXT I
1880 LPRINT E$;"%0"; 'Select normal character
1890 SS$=E$+"S1" 'Subscript
1900 GOSUB 2520
1910 LPRINT E$;"%1"; 'Select download character
1920 FOR I=1 TO 5
1930 LPRINT CHR$(60); 'Print download character
1940 NEXT I
1950 LPRINT E$;"%0"; 'Select normal character
1960 LPRINT E$;"T"; 'Cancel superscript
1970 LPRINT H$;RM$;"Dot graphics:"
1980 RESTORE 3170
1990 LPRINT E$;"A";CHR$(8); 'Set 8/60" line spacing
2000 FOR I=1 TO 3
2010 LPRINT E$;"f0";CHR$(8);
2020 LPRINT E$;"*";CHR$(33);CHR$(240);CHR$(0);
2030 FOR J=1 TO 240*3
2040 READ DAT
2050 LPRINT CHR$(DAT);
2060 NEXT J
2070 LPRINT
2080 NEXT I
2090 LPRINT E$;"@" 'Initialize printer
2100 END
2500 '
2510 ' SUBROUTINES
2520 ' Define super/subscript download character
2530 LPRINT SS$; 'Select super/subscript
2540 LPRINT E$;"&";CHR$(0);CHR$(60);CHR$(60);
2550 RESTORE 3010
2560 READ LS :LPRINT CHR$(LS);
2570 READ CW :LPRINT CHR$(CW);
2580 READ RS :LPRINT CHR$(RS);
2590 FOR M=1 TO CW*2
2600 READ MM
2610 LPRINT CHR$(MM);
2620 NEXT M

```

```

2630 RETURN
2640 '
2650 ' Define LQ pica download character
2660 LPRINT C$;
2670 LPRINT E$;"&";CHR$(0);CHR$(60);CHR$(60);
2680 RESTORE 3070
2690 READ LS :LPRINT CHR$(LS);
2700 READ CW :LPRINT CHR$(CW);
2710 READ RS :LPRINT CHR$(RS);
2720 FOR M=1 TO CW*3
2730 READ MM
2740 LPRINT CHR$(MM);
2750 NEXT M
2760 RETURN
3000 ' DATA
3010 ' Super/subscript download character data
3020 DATA 9, 19, 8
3030 DATA 12, 0, 16, 0, 44, 0, 80,120, 32,128, 95,120, 32,128
3040 DATA 95,120, 32,128, 65,120, 32,128, 95,120, 32,128, 95,120
3050 DATA 32,128, 80,120, 44, 0, 16, 0, 12, 0
3060 '
3070 ' LQ pica download characer data
3080 DATA 3, 31, 2
3090 DATA 0, 0, 0, 7, 0, 0, 8, 0, 0, 23, 0, 0, 40, 0, 0
3100 DATA 19, 15,192, 40, 16, 0, 80, 47,192, 32, 80, 0, 80,175,192
3110 DATA 47, 80, 0, 80,175,192, 47, 80, 0, 80,163,192, 33, 64, 0
3120 DATA 80,163,192, 33, 64, 0, 80,163,192, 47, 80, 0, 80,175,192
3130 DATA 47, 80, 0, 80,175,192, 32, 80, 0, 80, 47,192, 40, 16, 0
3140 DATA 19, 15,192, 40, 0, 0, 23, 0, 0, 8, 0, 0, 7, 0, 0
3150 DATA 0, 0, 0
3160 '
3170 ' Dot graphics data
3180 ' 1ST LINE
3190 DATA 0, 0, 0, 0, 0, 0, 0, 0, 0, 0, 0, 0, 0, 0, 0, 0
3200 DATA 0, 0, 0, 0, 0, 0, 0, 0, 0, 0, 0, 0, 0, 0, 0, 0
3210 DATA 0, 0, 0, 0, 0, 0, 0, 0, 0, 0, 0, 0, 0, 0, 0, 0
3220 DATA 0, 0, 0, 0, 0, 0, 0, 0, 0, 0, 0, 0, 0, 0, 0, 0
3230 DATA 0, 0, 0, 0, 0, 0, 0, 0, 0, 0, 0, 127,255, 0,255,255
3240 DATA 1,255,255, 3, 0, 0, 7, 0, 0, 7, 0, 0, 15, 0, 0
3250 DATA 31, 0, 0, 31, 0, 0, 31, 0, 0, 31, 0, 0, 31, 0, 0, 0
3260 DATA 31, 0, 0, 31, 0, 0, 31, 0, 0, 31, 0, 0, 31, 0, 0, 0
3270 DATA 31, 0, 0, 31, 0, 0, 31, 0, 0, 31, 0, 0, 31, 0, 0, 0
3280 DATA 31, 0, 0, 31,128, 0, 31,224, 0, 31,248, 0, 31,255, 0
3290 DATA 31,255,224, 15,255,248, 7,255,255, 1,255,255, 0,127,255
3300 DATA 0, 7,255, 0, 0,255, 0, 0, 63, 0, 0, 63, 0, 0,248
3310 DATA 0, 3,192, 0, 63, 0, 0,248, 0, 1,128, 0, 3, 0, 0
3320 DATA 7, 0, 0, 15, 0, 0, 15, 0, 0, 31, 0, 0, 31, 0, 0
3330 DATA 31, 0, 0, 31, 0, 0, 31, 0, 0, 31, 0, 0, 31, 0, 0
3340 DATA 31, 0, 0, 31, 0, 0, 31, 0, 0, 31, 0, 0, 31, 0, 0
3350 DATA 31, 0, 0, 31, 0, 0, 31, 0, 0, 31, 0, 0, 31, 0, 0
3360 DATA 31,255,255, 31,255,255, 31,255,255, 31,255,255, 31,255,255, 31,255,255
3370 DATA 31,255,255, 15,255,255, 0, 0, 0, 0, 0, 0, 0, 0, 0
3380 DATA 0, 0, 0, 0, 0, 0, 0, 0, 0, 0, 0, 0, 0, 0, 0, 0
3390 DATA 0, 0, 0, 0, 0, 0, 0, 0, 0, 0, 0, 0, 0, 0, 0, 0
3400 DATA 0, 0, 0, 0, 0, 60, 0, 3,255, 0, 11,195, 0, 28, 0
3410 DATA 0, 12, 0, 0, 96, 0, 0,192, 0, 0,192, 0, 1,128, 0
3420 DATA 3, 0, 0, 3, 0, 0, 7, 0, 0, 7, 0, 0, 15, 0, 0
3430 DATA 15, 0, 0, 31, 0, 0, 31, 0, 0, 31, 0, 0, 31, 0, 0, 15
3440 DATA 31, 0, 31, 31, 0, 31, 31, 0, 31, 31, 0, 31, 31, 0, 31
3450 DATA 31, 0, 31, 31, 0, 31, 31, 0, 31, 31, 0, 31, 31, 0, 31
3460 DATA 31, 0, 31, 31, 0, 31, 31, 0, 31, 31, 0, 31, 31, 0, 31
3470 DATA 31, 0, 31, 31, 0, 31, 31, 0, 31, 31, 0, 31, 31, 0, 63
3480 DATA 31,255,255, 31,255,255, 31,255,247, 31,255,231, 31,255,199
3490 DATA 15,255,135, 7,255, 7, 0, 0, 3, 0, 0, 1, 0, 0, 0
3500 DATA 0, 0, 0, 0, 0, 0, 0, 0, 0, 0, 0, 0, 0, 0, 0, 0
3510 DATA 0, 0, 0, 0, 0, 0, 0, 0, 0, 0, 0, 0, 0,254, 0

```

3520 DATA 1,255,240, 3,135,255, 7, 0, 63, 15, 0, 0, 15, 0, 0
3530 DATA 31, 0, 0, 31, 0, 0, 31, 0, 0, 31, 0, 0, 31, 0, 0
3540 DATA 31, 0, 0, 31, 0, 0, 31, 0, 0, 31,128, 0, 31,128, 0
3550 DATA 31,192, 0, 31,255, 0, 31,255,255, 31,255,255, 31,255,255
3560 DATA 31,255,255, 15,255,255, 7,255,255, 0,255,240, 1,254, 0
3570 DATA 1,240, 0, 3,128, 0, 7, 0, 0, 15, 0, 0, 31, 0, 0
3580 DATA 31, 0, 0, 31, 0, 0, 31, 0, 0, 31, 0, 0, 31, 0, 0
3590 DATA 31, 0, 0, 31, 0, 0, 31, 0, 0, 31,128, 0, 31,128, 0
3600 DATA 31,192, 0, 31,240, 0, 31,255, 0, 31,255,240, 31,255,255
3610 DATA 31,255,255, 7,255,255, 0,255,255, 0,255,255, 1,255,240
3620 DATA 3,192, 0, 7,128, 0, 15, 0, 0, 31, 0, 0, 31, 0, 0
3630 DATA 31, 0, 0, 31, 0, 0, 31, 0, 0, 31, 0, 0, 31, 0, 0
3640 DATA 31, 0, 0, 31, 0, 0, 31, 0, 0, 31, 0, 15, 31,135,255
3650 DATA 31,255,255, 31,255,255, 31,255,255, 31,255,255, 31,255,240
3660 DATA 15,252, 0, 47,128, 0, 0, 0, 0, 0, 0, 0, 0, 0, 0
3670 2ND LINE
3680 DATA 0, 0, 0, 0, 0, 0, 0, 0, 0, 0, 0, 0, 0, 0, 0
3690 DATA 0, 0, 0, 0, 0, 0, 0, 0, 0, 0, 0, 0, 0, 0, 0
3700 DATA 0, 0, 0, 0, 0, 0, 0, 0, 0, 0, 0, 0, 0, 0, 0
3710 DATA 0, 0, 0, 0, 0, 0, 0, 0, 0, 0, 0, 0, 0, 0, 0
3720 DATA 0, 0, 0, 0, 0, 0, 0, 0, 0, 0, 255, 255, 255, 255, 255, 255
3730 DATA 255, 255, 255, 0, 0, 0, 0, 0, 0, 0, 0, 0, 0, 0, 0
3740 DATA 0, 0, 0, 0, 0, 0, 0, 0, 0, 0, 0, 0, 0, 0, 0
3750 DATA 0, 0, 0, 0, 0, 0, 0, 0, 0, 0, 0, 0, 0, 0, 0
3760 DATA 255, 255, 255, 31, 255, 255, 7, 255, 255, 0, 255, 255, 0, 31, 255
3770 DATA 0, 3, 255, 0, 0, 255, 0, 0, 31, 0, 0, 7, 0, 0, 0
3780 DATA 0, 0, 0, 0, 0, 0, 0, 0, 0, 0, 224, 0, 0, 252, 0, 0
3790 DATA 254, 0, 0, 248, 0, 0, 192, 0, 0, 0, 0, 0, 0, 0, 0
3800 DATA 0, 0, 0, 0, 0, 0, 0, 0, 0, 0, 0, 0, 7, 0, 0, 63
3810 DATA 0, 1, 255, 0, 15, 255, 0, 127, 255, 1, 255, 255, 15, 255, 255
3820 DATA 255, 255, 255, 0, 0, 0, 0, 0, 0, 0, 0, 0, 0, 0, 0
3830 DATA 0, 0, 0, 0, 0, 0, 0, 0, 0, 0, 0, 0, 0, 0, 0
3840 DATA 0, 0, 0, 0, 0, 0, 0, 0, 0, 0, 0, 0, 0, 0, 0
3850 DATA 255, 255, 255, 255, 255, 255, 255, 255, 255, 255, 255, 255, 255, 255, 255
3860 DATA 255, 255, 255, 255, 255, 255, 0, 0, 0, 0, 0, 0, 0, 0, 0
3870 DATA 0, 0, 0, 0, 0, 0, 0, 0, 0, 0, 0, 0, 0, 0, 0
3880 DATA 0, 0, 0, 0, 0, 0, 0, 0, 0, 0, 0, 0, 0, 0, 0
3890 DATA 0, 7, 224, 0, 63, 252, 128, 120, 31, 192, 224, 3, 97, 128, 0
3900 DATA 59, 0, 0, 30, 0, 0, 14, 0, 0, 12, 0, 0, 12, 0, 0
3910 DATA 0, 0, 0, 0, 0, 0, 0, 0, 0, 0, 0, 0, 0, 0, 0
3920 DATA 0, 0, 0, 0, 0, 0, 0, 0, 0, 0, 0, 0, 0, 0, 63, 0
3930 DATA 128, 127, 128, 128, 127, 128, 127, 128, 127, 128, 127, 128, 127, 128, 127, 128, 128, 255, 128
3940 DATA 223, 255, 128, 255, 255, 128, 255, 255, 0, 224, 0, 0, 224, 0, 0
3950 DATA 224, 0, 0, 224, 0, 0, 224, 0, 0, 224, 0, 0, 224, 0, 0
3960 DATA 224, 0, 0, 224, 0, 0, 224, 0, 0, 224, 0, 0, 224, 0, 0
3970 DATA 224, 0, 1, 224, 0, 3, 240, 0, 15, 255, 255, 255, 255, 255, 254
3980 DATA 255, 255, 254, 255, 255, 252, 255, 255, 248, 255, 255, 224, 255, 255, 128
3990 DATA 0, 0, 0, 0, 0, 0, 0, 0, 0, 0, 0, 0, 0, 0, 0
4000 DATA 0, 0, 0, 0, 0, 0, 0, 0, 0, 0, 0, 0, 0, 0, 0
4010 DATA 0, 0, 0, 0, 0, 0, 240, 0, 0, 255, 0, 0, 15, 248, 0
4020 DATA 0, 63, 0, 0, 3, 248, 0, 0, 31, 0, 0, 3, 0, 0, 0
4030 DATA 0, 0, 0, 0, 0, 0, 0, 0, 0, 0, 0, 0, 0, 0, 0
4040 DATA 0, 0, 0, 0, 0, 0, 0, 0, 0, 0, 255, 0, 0, 255, 224, 0
4050 DATA 255, 128, 0, 240, 0, 0, 0, 0, 0, 0, 0, 0, 0, 0, 0
4060 DATA 0, 0, 0, 0, 0, 0, 0, 0, 0, 0, 0, 0, 7, 0, 0, 127
4070 DATA 0, 7, 255, 0, 63, 255, 1, 255, 255, 31, 255, 255, 3, 255, 255
4080 DATA 0, 127, 254, 0, 7, 252, 0, 0, 127, 0, 0, 7, 0, 0, 0
4090 DATA 0, 0, 0, 0, 0, 0, 0, 0, 0, 0, 0, 0, 0, 128, 0, 0
4100 DATA 248, 0, 0, 255, 0, 0, 255, 192, 0, 128, 0, 0, 0, 0, 0
4110 DATA 0, 0, 0, 0, 0, 0, 0, 0, 0, 0, 0, 0, 0, 0, 0
4120 DATA 0, 0, 0, 0, 0, 0, 0, 0, 0, 0, 0, 0, 1, 0, 0, 63
4130 DATA 0, 31, 255, 7, 255, 255, 255, 255, 255, 255, 255, 255, 255, 255, 254
4140 DATA 255, 255, 192, 255, 248, 0, 255, 0, 0, 0, 0, 0, 0, 0, 0
4150 DATA 0, 0, 0, 0, 0, 0, 0, 0, 0, 0, 0, 0, 0, 0, 0
4160 3RD LINE
4170 DATA 0, 0, 0, 0, 0, 0, 0, 0, 0, 0, 0, 24, 0, 0, 56

4180 DATA 0, 0, 56, 0, 0, 120, 0, 0, 248, 0, 1, 248, 0, 1, 248
4190 DATA 0, 3, 248, 0, 7, 248, 0, 7, 248, 0, 15, 248, 0, 15, 248
4200 DATA 0, 31, 248, 0, 63, 248, 0, 127, 248, 0, 127, 248, 0, 255, 248
4210 DATA 0, 255, 248, 1, 255, 248, 3, 255, 248, 199, 255, 248, 247, 255, 248
4220 DATA 255, 255, 248, 31, 255, 240, 15, 255, 240, 15, 255, 224, 15, 255, 224
4230 DATA 15, 255, 192, 15, 255, 192, 15, 255, 192, 15, 255, 128, 15, 255, 128
4240 DATA 15, 255, 0, 15, 255, 0, 15, 255, 0, 15, 254, 0, 15, 254, 0
4250 DATA 252, 252, 24, 252, 252, 56, 249, 252, 248, 249, 252, 248, 243, 255, 248
4260 DATA 227, 255, 248, 231, 255, 248, 199, 255, 248, 231, 255, 248, 255, 255, 248
4270 DATA 31, 255, 248, 15, 255, 248, 15, 255, 248, 15, 255, 248, 15, 255, 248
4280 DATA 15, 255, 248, 15, 255, 248, 15, 255, 248, 15, 255, 248, 15, 207, 248
4290 DATA 31, 15, 248, 30, 31, 248, 252, 63, 248, 248, 127, 248, 240, 127, 240
4300 DATA 224, 255, 240, 225, 255, 240, 195, 255, 224, 199, 255, 192, 247, 255, 128
4310 DATA 255, 255, 128, 63, 255, 0, 31, 254, 0, 15, 254, 0, 15, 252, 0
4320 DATA 15, 248, 0, 15, 240, 0, 15, 240, 0, 15, 224, 0, 15, 192, 0
4330 DATA 15, 192, 0, 15, 128, 0, 15, 0, 0, 31, 0, 0, 62, 0, 0
4340 DATA 252, 0, 0, 252, 0, 0, 248, 0, 0, 240, 0, 224, 240, 0, 240
4350 DATA 224, 1, 240, 192, 1, 248, 0, 3, 248, 0, 3, 248, 0, 3, 248
4360 DATA 0, 7, 248, 0, 7, 248, 0, 63, 248, 0, 127, 248, 0, 127, 248
4370 DATA 0, 255, 248, 0, 255, 248, 1, 255, 248, 1, 255, 248, 1, 255, 248
4380 DATA 3, 255, 248, 3, 255, 248, 3, 255, 248, 131, 255, 248, 199, 255, 248
4390 DATA 103, 255, 248, 119, 255, 248, 55, 255, 248, 63, 255, 248, 31, 255, 248
4400 DATA 31, 255, 248, 31, 255, 248, 15, 255, 248, 15, 255, 248, 15, 255, 248
4410 DATA 15, 255, 248, 15, 255, 248, 15, 255, 248, 15, 255, 248, 15, 255, 240
4420 DATA 15, 255, 240, 15, 255, 224, 15, 255, 192, 15, 255, 192, 15, 254, 0
4430 DATA 15, 254, 0, 15, 254, 0, 15, 254, 0, 15, 254, 0, 15, 254, 0
4440 DATA 15, 252, 0, 15, 252, 0, 15, 248, 0, 15, 240, 0, 31, 240, 0
4450 DATA 31, 224, 0, 31, 192, 0, 55, 128, 0, 48, 0, 8, 96, 0, 24
4460 DATA 192, 0, 24, 128, 0, 56, 0, 0, 56, 0, 0, 120, 0, 0, 120
4470 DATA 0, 0, 248, 0, 0, 248, 0, 1, 248, 0, 1, 248, 0, 3, 248
4480 DATA 0, 3, 248, 0, 7, 248, 0, 7, 248, 0, 15, 248, 0, 15, 248
4490 DATA 0, 31, 248, 0, 31, 240, 0, 63, 240, 0, 63, 224, 0, 127, 224
4500 DATA 0, 127, 192, 0, 255, 192, 0, 255, 128, 1, 255, 128, 1, 255, 24
4510 DATA 3, 255, 56, 3, 255, 248, 231, 255, 248, 255, 255, 248, 31, 255, 248
4520 DATA 15, 255, 248, 15, 255, 248, 15, 255, 248, 15, 255, 248, 15, 255, 248
4530 DATA 15, 255, 248, 15, 255, 248, 15, 255, 248, 15, 255, 248, 15, 255, 240
4540 DATA 15, 255, 240, 15, 255, 240, 15, 255, 224, 15, 255, 224, 15, 255, 192
4550 DATA 15, 255, 192, 31, 255, 128, 254, 127, 128, 252, 127, 24, 248, 255, 56
4560 DATA 248, 255, 248, 240, 255, 248, 225, 255, 248, 193, 255, 248, 131, 255, 248
4570 DATA 3, 255, 248, 7, 255, 248, 135, 255, 248, 231, 255, 248, 255, 255, 248
4580 DATA 63, 255, 248, 31, 255, 248, 15, 255, 248, 15, 255, 248, 15, 255, 240
4590 DATA 15, 255, 240, 15, 255, 224, 15, 255, 192, 15, 255, 128, 15, 255, 0
4600 DATA 15, 254, 0, 15, 252, 0, 15, 248, 0, 15, 240, 0, 15, 224, 0
4610 DATA 15, 192, 0, 15, 0, 0, 62, 0, 0, 252, 0, 0, 248, 0, 0
4620 DATA 240, 0, 0, 224, 0, 0, 192, 0, 0, 128, 0, 0, 0, 0, 0
4630 DATA 0, 0, 0, 0, 0, 0, 0, 0, 0, 0, 0, 0, 0, 0, 0
4640 DATA 0, 0, 0, 0, 0, 0, 0, 0, 0, 0, 0, 0, 0, 0, 0

How the program works

This program begins by assigning a number of printer commands to BASIC string variables (lines 1000 to 1060). You can find most of these commands near the beginning of chapter 8.

The WIDTH "LPT1:" 255 statement in line 1080 means infinite line width. It prevents the IBM-PC from inserting unwanted carriage returns and line feeds in graphics data.

Actual printing begins in line 1090. Using the preassigned commands, the program prints samples of its different fonts, followed by samples of the print pitches, then some double and quadruple-sized printing.

Next comes the central attraction of the program: a line of text printed fourteen times in expanding and contracting loops to give a barrel effect. The work is done by four printer commands: a command setting the right margin (line 1400); a centering command (line 1420); a command to vary the line spacing (lines 1440 and 1490); and a command to micro-adjust the space between characters (lines 1450 and 1500).

Next the program returns to normal spacing and gives a demonstration of the printer's word-processing abilities: italic printing, bold printing, underlining, subscripts, etc.

The row of telephone symbols in the next printed line is created by downloading two new character patterns, which are printed in place of the character "<" (character 60). Details can be found in Chapter 9.

The final part of the program uses dot graphics to print an "M&W" logo. The dot pattern of the logo was originally laid out on graph paper, then converted to the data in lines 3180 to 4640 with the help of a calculator. Each number represents eight vertical dots. (See "Graphics commands" in Chapter 8 for details.)

The pattern is printed in three rows, each row is twenty-four dots high and 240 dots wide. Line 1990 sets the line spacing to 8/60 inch so that the rows will connect vertically. The loop in lines 2000 to 2080 does the printing in three passes of the print head.

The printout sample with this program is shown in page 7.

MEMO

Chapter 11

REFERENCE

SPECIFICATIONS

Printing system	Serial Impact Dot-matrix		
Printing speed	Pica	Elite	Semi-condensed
High-Speed Draft	210 cps	—	—
Draft	160 cps	192 cps	240 cps
Letter Quality	53 cps	64 cps	80 cps
Print direction	Bi-directional, logic-seeking Uni-directional, logic-seeking (selectable)		
Print head	24 pins Life: 200 million dots		
Line spacing	1/6, 1/8, n/60, n/72, n/180, n/216, n/360 inches		
Font styles			
Standard	Draft, High-Speed Draft, Roman, Sanserif, Courier, Prestige, Script		
Option [FC-1Z Cartridge]	Orator, Orator 2, Letter Gothic, Blippo, Cinema		
[FC-2Z Cartridge]	OCR-B, OCR-A, CODE 39, UPC/EAN		
[FC-3Z Cartridge]	TW-Light, H-Gothic, Orane		
[FC-4Z Cartridge]	Russian Roman, GOST, Cyrillic		
[FC-5Z Cartridge]	Old Style, Firenze		
[FC-10Z Cartridge]	SLQ Script		
[FC-11Z Cartridge]	SLQ Roman		
[FC-12Z Cartridge]	SLQ TW-Light		

Characters	ASCII	96
	International	16 sets (*)
	IBM special	111
	IBM block graphic	50
	IBM code page	6 sets (**)
	Download	255

* USA, France, Germany, England, Denmark I, Sweden, Italy, Spain I, Japan, Norway, Denmark II, Spain II, Latin America, Korea, Irish, Legal

** #437 (USA), #850 (Multi-Lingual), #860 (Portuguese), #861 (Icelandic), #863 (Canadian French), #865 (Nordic)

Number of columns	CPI	
Pica	10	80
Elite	12	96
Semi-condensed	15	120
Condensed pica	17.1	137
Condensed elite	20	160
Super-condensed	24	192
Proportional		Variable

Character matrix	Draft	LQ	SLQ
Pica	24 × 9	24 × 31	48 × 31
Elite	24 × 9	24 × 27	48 × 27
Semi-condensed			
(Standard/Epson mode)	16 × 7	16 × 21	32 × 21
(IBM mode)	24 × 9	24 × 16	48 × 16
Condensed pica	24 × 9	24 × 16	48 × 16
Condensed elite	24 × 9	24 × 16	48 × 16
Super-condensed	24 × 9	24 × 14	48 × 14
Proportional	—	24 × <i>n</i>	48 × <i>n</i>

Bit image dot-matrix	DPI	
8-pin normal	60	8 × 480
8-pin double	120	8 × 960
8-pin high-speed double *	120	8 × 960
8-pin quadruple *	240	8 × 1920
8-pin CRT I	80	8 × 640
8-pin CRT II	90	8 × 720

24-pin normal	60	24 × 480
24-pin double	120	24 × 960
24-pin CRT III	90	24 × 720
24-pin Triple	180	24 × 1440
24-pin Hex *	360	24 × 2880

* It is impossible to print adjacent dots in the mode marked with an asterisk (*).

Paper feedFriction or push tractor feed (standard)
Bottom feed with pull tractor (option)

Paper feed speed3.4 inches/second max

Paper specifications

Cut sheet

Width7.2" ~ 11.0" (182.0 ~ 279.4 mm)
Length5.5" ~ 14.3" (139.7 ~ 364.0 mm)
Thickness0.07 ~ 0.12 mm
Weight52 ~ 90 g/m²
45 ~ 77 kg
14 ~ 24 lb

Fanfold (continuous)

Width4.0" ~ 10.0" (101.6 ~ 254.0 mm)
LengthMinimum 5.5" (139.7 mm)
ThicknessSingle-ply paper 0.07 ~ 0.12 mm
Total for multi-part forms 0.25 mm
Weight52 ~ 82 g/m²
45 ~ 70 kg
14 ~ 22 lb

CopiesOriginal + 2 copies

Maximum buffer sizeWithout Download 15.6 kB
With Download 256 Bytes

EmulationsStandard mode: Epson LQ-860/850, NEC
24-wire Graphics com-
mands
IBM mode: IBM Proprinter X24E,
Proprinter 24P, PS/1 printer

InterfaceCentronics parallel (standard)
RS-232C serial (option)

Ribbon typeOn-carriage, dedicated
Fabric ribbon (Black only)
Film ribbon (Black only)

Ribbon life

Film ribbon (FZ24)0.2 million characters (LQ pica)
Fabric ribbon (Z24)2 million characters (draft pica)
Long life fabric ribbon
(LZ24)4 million characters (draft pia)

Dimensions and Weight

Width440 mm (17.32")
Depth330 mm (12.99")
Width150 mm (5.91")
Weight6.4 Kg (14.1 lb)

Power supply120VAC, 220VAC, 240VAC, 50/60 Hz
(varies according to the country of pur-
chase)

OptionsFilm ribbon cartridge (FZ24)
Long life fabric ribbon cartridge (LZ24)
Single-bin Automatic Sheet Feeder
(SF-10DS)
Pull Tractor Unit (PT-10ZS)
Font cartridge (FC-1Z, FC-2Z, FC-3Z, FC-
4Z, FC-5Z, FC-10Z, FC-11Z, FC-12Z)
RAM cartridge (RC-32Z, DC-32Z)
Serial-Parallel Converter (SPC-8K)

PINOUT OF INTERFACE CONNECTOR

The following describes the pinout of the interface connector (signals which are low when active are overlined).

Parallel interface

Pin	Name	Function
1	<u>STROBE</u>	Goes from high to low (for $\geq 0.5 \mu\text{s}$) when active
2	DATA0	High when active
3	DATA1	High when active
4	DATA2	High when active
5	DATA3	High when active
6	DATA4	High when active
7	DATA5	High when active
8	DATA6	High when active
9	DATA7	High when active
10	ACK	5 μs low pulse acknowledges receipt of data
11	BUSY	Low when printer ready to receive data
12	PAPER	High when paper out. Can be disabled with EDS setting
13	SELECT	High when printer is on-line
14, 15	N/C	
16	SIGNAL GND	Signal ground
17	CHASSIS	Chassis ground (isolated from signal ground)
18	+5V	+5V DC output from printer
19 ~ 30	GND	Twisted pair ground return
31	RESET	When this input signal is low, printer is reset
32	<u>ERROR</u>	Outputs low when printer cannot continue, due to an error
33	EXT GND	External ground
34, 35	N/C	
36	<u>SELECT IN</u>	Always high

Serial Interface

Pin	Name	Function
1	GND	Printer's chassis ground.
2	TXD	This pin carries data from the printer.
3	RXD	This pin carries data to the printer.
4	RTS	This pin is always set space.
5	CTS	This pin is Space when the computer is ready to send data. This printer does not check this pin.
6	N/C	
7	GND	Signal ground.
8 ~ 10	N/C	
11	RCH	This printer turn this pin Space when it is ready to receive data. This line carries the same signal as pin 20.
12	N/C	
13	GND	Signal ground.
14 ~ 19	N/C	
20	DTR	This printer turns this pin Space when it is ready to receive data.
21 ~ 25	N/C	

CHARACTER SETS

The following tables show the standard and IBM character sets.

The decimal character code of each character is shown in an inset to the lower right of the character.

The hexadecimal code can be found by reading the entires at the top and left edges of the table. For example, the character "A" is in column 4 and row 1, so its hexadecimal character code is 41. This is equivalent ($4 \times 16 + 1 = 65$) to decimal 65, the number in the inset.

Control codes recognized by this printer are indicated by abbreviations inside pointed brackets <>.

	0	1	2	3	4	5	6	7
0	<NUL> 0	16	32	48	@ 64	P 80	` 96	p 112
1	<DC1> 1	! 17	33	49	A 65	Q 81	a 97	q 113
2	<DC2> 2	" 18	34	50	B 66	R 82	b 98	r 114
3	<DC3> 3	# 19	35	51	C 67	S 83	c 99	s 115
"	<DC4> 4	\$ 20	36	52	D 68	T 84	d 100	t 116

Character

Hexadecimal value (high order)

Control code

Decimal value

Hexadecimal value (low order)

Standard character set #2

	0	1	2	3	4	5	6	7
0	<NUL> 0	16	32	48	64	80	96	p
1	<DC1> 1	17	33	49	65	81	97	q
2	<DC2> 2	18	34	50	66	82	98	r
3	♥ 3	<DC3> 19	35	51	67	83	99	s
4	♦ 4	<DC4> 20	36	52	68	84	100	t
5	♣ 5	§ 21	% 37	53	69	85	101	u
6	♠ 6	<SYN> 22	& 38	54	70	86	102	v
7	<BEL> 7	23	' 39	55	71	87	103	w
8	<BS> 8	<CAN> 24	(40	56	72	88	104	x
9	<HT> 9	 25) 41	57	73	89	105	y
A	<LF> 10	26	* 42	58	74	90	106	z
B	<VT> 11	<ESC> 27	+ 43	59	75	91	107	{
C	<FF> 12	<FS> 28	, 44	60	76	92	108	
D	<CR> 13	29	- 45	= 61	77	93	109	}
E	<SO> 14	30	. 46	> 62	78	94	110	~
F	<SI> 15	31	/ 47	? 63	79	95	111	 127

	8	9	A	B	C	D	E	F
0	à 128	š 144		0 176	@ 192	P 208	` 224	p 240
1	è 129	ß 145	! 161	1 177	A 193	Q 209	a 225	q 241
2	ù 130	Æ 146	" 162	2 178	B 194	R 210	b 226	r 242
3	ò 131	æ 147	# 163	3 179	C 195	S 211	c 227	s 243
4	ì 132	ø 148	\$ 164	4 180	D 196	T 212	d 228	t 244
5	ó 133	ø 149	% 165	5 181	E 197	U 213	e 229	u 245
6	£ 134	“ 150	& 166	6 182	F 198	V 214	f 230	v 246
7	í 135	À 151	' 167	7 183	G 199	W 215	g 231	w 247
8	ç 136	Ö 152	(168	8 184	H 200	X 216	h 232	x 248
9	Ñ 137	Ù 153) 169	9 185	I 201	Y 217	i 233	y 249
A	ñ 138	ä 154	* 170	: 186	J 202	Z 218	j 234	z 250
B	α 139	ö 155	+ 171	; 187	K 203	l 219	k 235	{ 251
C	ß 140	ü 156	, 172	< 188	L 204	\ 220	l 236	!' 252
D	À 141	É 157	- 173	= 189	M 205	J 221	m 237	} 253
E	á 142	é 158	. 174	> 190	N 206	^ 222	n 238	~ 254
F	ç 143	¥ 159	/ 175	? 191	O 207	- 223	o 239	

International character sets

When an international character set is selected by a command from software, the following changes are made in the Standard Italic character set:

Country	35	36	64	88	90	91	92	93	94	96	123	124	125	126
U.S.A.	#	\$	@	X	Z	[\]	^	`	{		}	~
FRANCE	#	\$	à	X	Z	°	ç	§	^	`	é	ù	è	¨
GERMANY	#	\$	§	X	Z	Ä	Ö	Ü	^	`	ä	ö	ü	ß
ENGLAND	£	\$	@	X	Z	[\]	^	`	{		}	~
DENMARK 1	#	\$	@	X	Z	Æ	Ø	Å	^	`	æ	ø	å	~
SWEDEN	#	κ	É	X	Z	Ä	Ö	Å	Ü	é	ä	ö	å	ü
ITALY	#	\$	@	X	Z	°	\	é	^	ù	à	ò	è	ì
SPAIN 1	₧	\$	@	X	Z	;	Ñ	¿	^	`	¨	ñ	}	~
JAPAN	#	\$	@	X	Z	[¥]	^	`	{		}	~
NORWAY	#	κ	É	X	Z'	Æ	Ø	Å	Ü	é	æ	ø	å	ü
DENMARK 2	#	\$	É	X	Z	Æ	Ø	Å	Ü	é	æ	ø	å	ü
SPAIN 2	#	\$	á	X	Z	;	Ñ	¿	é	`	í	ñ	ó	ú
LATIN AMERICA	#	\$	á	X	Z	;	Ñ	¿	é	ü	í	ñ	ó	ú
KOREA	#	\$	@	X	Z	[₩]	^	`	{		}	~
IRISH	#	\$	@	Ú	˘	[\]	^	`	Á	É	Ó	~
LEGAL	#	\$	§	X	Z	°	'	"	¶	`	©	®	†	™

The command for selecting the international character set is:

<ESC> "R" *n*

Where *n* means character code *n*, i.e. CHR\$(*n*) in BASIC. The values of *n* are:

0	U.S.A.	6	Italy	12	Latin America
1	France	7	Spain I	13	Korea
2	Germany	8	Japan	14	Irish
3	England	9	Norway	64	Legal
4	Denmark I	10	Denmark II		
5	Sweden	11	Spain II		

IBM character set #2

Code Page #437 (U.S.A.)

	0	1	2	3	4	5	6	7
0	<NUL> 0	16	32	0	@	P	`	p
1	1	<DC1> 17	33	1	A	Q	a	q
2	2	<DC2> 18	34	2	B	R	b	r
3	3	<DC3> 19	35	3	C	S	c	s
4	4	<DC4> 20	36	4	D	T	d	t
5	5	21	37	5	E	U	e	u
6	6	<SYN> 22	38	6	F	V	f	v
7	<BEL> 7	23	39	7	G	W	g	w
8	<BS> 8	<CAN> 24	40	8	H	X	h	x
9	<HT> 9	 25	41	9	I	Y	i	y
A	<LF> 10	26	42	:	J	Z	j	z
B	<VT> 11	<ESC> 27	43	;	K	[k	{
C	<FF> 12	<FS> 28	44	<	L	\	l	
D	<CR> 13	29	45	=	M]	m	}
E	<SD> 14	30	46	>	N	^	n	~
F	<SI> 15	31	47	?	O	_	o	

	8	9	A	B	C	D	E	F
0	Ç 128	É 144	á 160	⋯ 176	Ł 192	⋈ 208	α 224	≡ 240
1	ü 129	æ 145	í 161	⋯ 177	⊥ 193	⸗ 209	β 225	± 241
2	é 130	Æ 146	ó 162	⋯ 178	⊤ 194	Π 210	Γ 226	≥ 242
3	â 131	ô 147	ú 163	 179	† 195	⋈ 211	π 227	≤ 243
4	ä 132	ö 148	ñ 164	‡ 180	- 196	Ł 212	Σ 228	∫ 244
5	à 133	ò 149	ñ 165	‡ 181	† 197	F 213	σ 229	J 245
6	á 134	û 150	ä 166	‡ 182	‡ 198	π 214	μ 230	÷ 246
7	ç 135	ù 151	ó 167	π 183	‡ 199	‡ 215	τ 231	≈ 247
8	ê 136	ÿ 152	¿ 168	‡ 184	Ł 200	≠ 216	Φ 232	° 248
9	ë 137	ö 153	ƒ 169	‡ 185	ƒ 201	J 217	Θ 233	• 249
A	è 138	Û 154	ƒ 170	‡ 186	⋈ 202	Γ 218	Ω 234	• 250
B	ï 139	ϕ 155	½ 171	π 187	⸗ 203	■ 219	δ 235	√ 251
C	î 140	£ 156	¼ 172	⋈ 188	‡ 204	■ 220	∞ 236	n 252
D	ì 141	¥ 157	¡ 173	⋈ 189	= 205	■ 221	∅ 237	² 253
E	Ë 142	ƒ 158	« 174	⋈ 190	‡ 206	■ 222	€ 238	▪ 254
F	À 143	f 159	» 175	γ 191	± 207	■ 223	∩ 239	

Code Page #850 (Multi-lingual)

Other characters are identical to Code Page #437.

	8	9	A	B	C	D	E	F
0	Ç 128	É 144	á 160	◌̇ 176	Ł 192	ð 208	ó 224	- 240
1	ü 129	æ 145	í 161	◌̇ 177	ł 193	Ð 209	β 225	± 241
2	é 130	Æ 146	ó 162	◌̇ 178	Ṭ 194	È 210	ò 226	= 242
3	â 131	ô 147	ú 163	 179	ł 195	È 211	ò 227	¾ 243
4	ä 132	ö 148	ñ 164	ł 180	- 196	È 212	ö 228	¶ 244
5	à 133	ò 149	Ñ 165	À 181	ł 197	ı 213	Ö 229	§ 245
6	â 134	û 150	ä 166	À 182	ā 198	ı 214	μ 230	÷ 246
7	ç 135	ù 151	ó 167	À 183	Ā 199	ı 215	þ 231	· 247
8	ê 136	ÿ 152	ı 168	© 184	Ł 200	ı 216	þ 232	° 248
9	ë 137	ö 153	® 169	ł 185	ł 201	ı 217	ú 233	· 249
A	è 138	Û 154	ı 170	 186	ł 202	ı 218	Û 234	· 250
B	ï 139	ø 155	½ 171	ł 187	ł 203	■ 219	Û 235	¹ 251
C	î 140	£ 156	¾ 172	ł 188	ł 204	■ 220	ý 236	³ 252
D	ì 141	Ø 157	ı 173	φ 189	= 205	ı 221	ÿ 237	² 253
E	Ā 142	× 158	« 174	¥ 190	ł 206	ı 222	- 238	■ 254
F	Ā 143	f 159	» 175	ł 191	ı 207	■ 223	· 239	

Code Page #860 (Portuguese)

Other characters are identical to Code Page #437.

	8	9	A	B	C	D	E	F
0	Ç 128	É 144	á 160	• 176	Ł 192	⋈ 208	α 224	≡ 240
1	ü 129	À 145	í 161	• 177	⊥ 193	⸮ 209	β 225	± 241
2	é 130	È 146	ó 162	• 178	⸮ 194	π 210	Γ 226	≥ 242
3	â 131	ô 147	ú 163	 179	† 195	⋈ 211	π 227	≤ 243
4	ã 132	õ 148	ñ 164	† 180	- 196	Ł 212	Σ 228	∫ 244
5	à 133	ò 149	Ñ 165	‡ 181	† 197	F 213	σ 229	∫ 245
6	Á 134	Ú 150	ã 166	‡ 182	‡ 198	π 214	μ 230	÷ 246
7	ç 135	ù 151	◊ 167	π 183	‡ 199	‡ 215	τ 231	≈ 247
8	ê 136	Ï 152	¿ 168	ƒ 184	Ł 200	‡ 216	Φ 232	° 248
9	Ê 137	Ï 153	Ò 169	‡ 185	ƒ 201	∟ 217	Θ 233	• 249
A	è 138	Ù 154	¬ 170	‡ 186	⋈ 202	∟ 218	Ω 234	• 250
B	Í 139	Φ 155	½ 171	∩ 187	⸮ 203	■ 219	δ 235	√ 251
C	Ô 140	£ 156	¾ 172	∩ 188	‡ 204	■ 220	∞ 236	∞ 252
D	ì 141	Û 157	ì 173	⋈ 189	= 205	■ 221	∅ 237	² 253
E	À 142	Ř 158	« 174	∩ 190	⋈ 206	■ 222	€ 238	▪ 254
F	Á 143	Ó 159	» 175	∩ 191	⋈ 207	■ 223	∩ 239	

Code Page #861 (Icelandic)

Other characters are identical to Code Page #437.

	8	9	A	B	C	D	E	F
0	Ç 128	É 144	á 160	ð 176	Ł 192	Ɑ 208	α 224	≡ 240
1	ü 129	æ 145	í 161	þ 177	Ł 193	Ɱ 209	β 225	± 241
2	é 130	Æ 146	ó 162	ð 178	Ŧ 194	Π 210	Γ 226	≥ 242
3	â 131	ô 147	ú 163	 179	† 195	Ɐ 211	π 227	≤ 243
4	ä 132	ö 148	Á 164	† 180	— 196	ƚ 212	Σ 228	∫ 244
5	à 133	þ 149	í 165	‡ 181	† 197	ƚ 213	σ 229	∫ 245
6	ã 134	û 150	ó 166	‡ 182	ƚ 198	π 214	μ 230	÷ 246
7	ç 135	ÿ 151	ú 167	π 183	‡ 199	‡ 215	τ 231	≈ 247
8	ê 136	ý 152	í 168	ƚ 184	Ł 200	‡ 216	Φ 232	° 248
9	ë 137	ö 153	ƚ 169	‡ 185	ƚ 201	∫ 217	Θ 233	• 249
A	è 138	Û 154	ƚ 170	‡ 186	Ł 202	ƚ 218	Ω 234	• 250
B	Ð 139	ø 155	½ 171	π 187	π 203	■ 219	δ 235	√ 251
C	ð 140	£ 156	¼ 172	∫ 188	‡ 204	■ 220	∞ 236	ⁿ 252
D	Ð 141	Ø 157	í 173	Ɑ 189	= 205	■ 221	ø 237	² 253
E	Ä 142	ƚ 158	« 174	‡ 190	‡ 206	■ 222	ε 238	■ 254
F	À 143	ƚ 159	» 175	ƚ 191	Ł 207	■ 223	∩ 239	

Code Page #863 (Canadian French)

Other characters are identical to Code Page #437.

	8	9	A	B	C	D	E	F
0	Ç 128	Ê 144	Ï 160	Ï 176	Ł 192	Ɑ 208	α 224	≡ 240
1	ü 129	È 145	Ë 161	Ë 177	Ł 193	Ɱ 209	β 225	± 241
2	é 130	Ê 146	Ó 162	Ó 178	Ŧ 194	Π 210	Γ 226	≥ 242
3	â 131	ô 147	ú 163	ú 179	Ŧ 195	Ɑ 211	π 227	≤ 243
4	À 132	È 148	Ë 164	Ë 180	— 196	Ł 212	Σ 228	∫ 244
5	à 133	Ï 149	Ë 165	Ë 181	† 197	F 213	σ 229	∫ 245
6	¶ 134	û 150	³ 166	¶ 182	ƒ 198	π 214	μ 230	÷ 246
7	ç 135	ù 151	— 167	π 183	¶ 199	¶ 215	τ 231	≈ 247
8	ê 136	œ 152	† 168	ƒ 184	Ł 200	≠ 216	Φ 232	° 248
9	ë 137	ó 153	ƒ 169	¶ 185	¶ 201	∫ 217	Θ 233	• 249
A	è 138	ù 154	ƒ 170	¶ 186	Ɑ 202	ƒ 218	Ω 234	• 250
B	ï 139	φ 155	½ 171	¶ 187	Ɱ 203	■ 219	δ 235	√ 251
C	î 140	£ 156	¾ 172	¶ 188	¶ 204	■ 220	∞ 236	n 252
D	= 141	Û 157	¾ 173	Ɑ 189	= 205	■ 221	∅ 237	² 253
E	À 142	Ô 158	« 174	ƒ 190	Ɱ 206	■ 222	ε 238	▪ 254
F	§ 143	f 159	» 175	ƒ 191	Ɑ 207	■ 223	∩ 239	

Code Page #865 (Nordic)

Other characters are identical to Code Page #437.

	8	9	A	B	C	D	E	F
0	Ç 128	É 144	á 160	⋯ 176	Ł 192	⋈ 208	α 224	≡ 240
1	ü 129	æ 145	í 161	⋯ 177	Ł 193	⋈ 209	β 225	± 241
2	é 130	Æ 146	ó 162	⋯ 178	Ŧ 194	Π 210	Γ 226	≥ 242
3	â 131	ô 147	ú 163	 179	† 195	⋈ 211	π 227	≤ 243
4	ä 132	ö 148	ñ 164	‡ 180	— 196	⋈ 212	Σ 228	∫ 244
5	à 133	ò 149	ñ 165	‡ 181	† 197	ƒ 213	σ 229	∫ 245
6	â 134	û 150	ä 166	 182	ƒ 198	π 214	μ 230	÷ 246
7	ç 135	ù 151	ó 167	π 183	 199	 215	τ 231	≈ 247
8	ê 136	ÿ 152	¿ 168	‡ 184	⋈ 200	‡ 216	Φ 232	° 248
9	ë 137	ö 153	ƒ 169	 185	ƒ 201	∫ 217	Θ 233	• 249
A	è 138	ü 154	ƒ 170	 186	⋈ 202	ƒ 218	Ω 234	• 250
B	ï 139	ø 155	½ 171	∩ 187	⋈ 203	■ 219	δ 235	√ 251
C	î 140	£ 156	¼ 172	∩ 188	 204	■ 220	∞ 236	∞ 252
D	ì 141	Ø 157	ı 173	⋈ 189	= 205	■ 221	∅ 237	² 253
E	Ä 142	Ř 158	« 174	∩ 190	⋈ 206	■ 222	€ 238	■ 254
F	Å 143	ƒ 159	α 175	∩ 191	⋈ 207	■ 223	∩ 239	■ 255

Character set #1

Other characters are identical to character set #2.

The duplication of control codes enables systems with a 7-bit interface to obtain control functions when the most significant bit is set to 1 by the <ESC> “>” command in the standard mode.

	0	1
0	<NUL> 0	16
1	1	<DC1> 17
2	2	<DC2> 18
3	3	<DC3> 19
4	4	<DC4> 20
5	5	21
6	6	<SYN> 22
7	<BEL> 7	23
8	<BS> 8	<CAN> 24
9	<HT> 9	 25
A	<LF> 10	26
B	<VT> 11	<ESC> 27
C	<FF> 12	<FS> 28
D	<CR> 13	29
E	<SD> 14	30
F	<SI> 15	31

	8	9
0	<NUL> 128	144
1	129	<DC1> 145
2	130	<DC2> 146
3	131	<DC3> 147
4	132	<DC4> 148
5	133	149
6	134	<SYN> 150
7	<BEL> 135	151
8	<BS> 136	<CAN> 152
9	<HT> 137	 153
A	<LF> 138	154
B	<VT> 139	<ESC> 155
C	<FF> 140	<FS> 156
D	<CR> 141	157
E	<SD> 142	158
F	<SI> 143	159

IBM special character set

Additional characters can be printed by special commands.

	0	1
0	∅ 0	▶ 16
1	☺ 1	◀ 17
2	☹ 2	↓ 18
3	♥ 3	!! 19
4	♦ 4	¶ 20
5	♣ 5	§ 21
6	♠ 6	- 22
7	• 7	↑ 23
8	◼ 8	↑ 24
9	◊ 9	↓ 25
A	◻ 10	→ 26
B	♂ 11	← 27
C	♀ 12	┌ 28
D	♪ 13	↔ 29
E	♫ 14	▲ 30
F	✱ 15	▼ 31

PROPORTIONAL SPACING TABLE

This table lists the widths of your printer's proportional characters, for Standard mode and IBM mode.

The values given are in 360ths of an inch. For example, a value of 36 is 36/360ths of an inch. You may need to enter these widths into a special table for your processing program so it can calculate the number of proportional characters that will fit on a line.

The following width table shows each character, its ASCII code (decimal) for each character set, and its width for Standard normal mode, Standard super/subscript mode, and IBM mode.

Character code							Chr.	Proportional width		
Std.	#437	#850	#860	#861	#863	#865		Normal	Super/Sub	IBM
-	0	0	0	0	0	0	∅	30	20	30
-	1	1	1	1	1	1	⊕	30	20	30
-	2	2	2	2	2	2	⊙	30	20	30
-	3	3	3	3	3	3	♥	30	20	30
-	4	4	4	4	4	4	♦	30	20	30
-	5	5	5	5	5	5	♣	30	20	30
-	6	6	6	6	6	6	♠	30	20	30
-	7	7	7	7	7	7	•	30	20	30
-	8	8	8	8	8	8	◼	30	20	30
-	9	9	9	9	9	9	◊	30	20	30
-	10	10	10	10	10	10	◻	30	20	30
-	11	11	11	11	11	11	♂	30	20	30
-	12	12	12	12	12	12	♀	30	20	30
-	13	13	13	13	13	13	♪	30	20	30
-	14	14	14	14	14	14	♫	30	20	30
-	15	15	15	15	15	15	⊛	30	20	30
-	16	16	16	16	16	16	▶	30	20	30
-	17	17	17	17	17	17	◀	30	20	30
-	18	18	18	18	18	18	↓	30	20	30
-	19	19	19	19	19	19	!!	30	20	30

Character code							Chr.	Proportional width		
Std.	#437	#850	#860	#861	#863	#865		Normal	Super/Sub	IBM
INT	20	20	20	20	20	20	¶	30	20	30
INT	21	21	21	21	21	21	§	30	20	30
-	22	22	22	22	22	22	-	30	20	30
-	23	23	23	23	23	23	‡	30	20	30
-	24	24	24	24	24	24	†	30	20	30
-	25	25	25	25	25	25	‡	30	20	30
-	26	26	26	26	26	26	→	30	20	30
-	27	27	27	27	27	27	←	30	20	30
-	28	28	28	28	28	28	⌊	30	20	30
-	29	29	29	29	29	29	↔	30	20	30
-	30	30	30	30	30	30	▲	30	20	30
-	31	31	31	31	31	31	▼	30	20	30
32	32	32	32	32	32	32		30	20	30
33	33	33	33	33	33	33	!	18	12	30
34	34	34	34	34	34	34	"	30	20	30
35	35	35	35	35	35	35	#	30	20	30
36	36	36	36	36	36	36	\$	30	20	30
37	37	37	37	37	37	37	%	36	24	30
38	38	38	38	38	38	38	&	36	24	36
39	39	39	39	39	39	39	'	18	12	18
40	40	40	40	40	40	40	(24	16	30
41	41	41	41	41	41	41)	24	16	30
42	42	42	42	42	42	42	*	30	20	30
43	43	43	43	43	43	43	+	30	20	30
44	44	44	44	44	44	44	,	18	12	30
45	45	45	45	45	45	45	-	30	20	30
46	46	46	46	46	46	46	.	18	12	30
47	47	47	47	47	47	47	/	30	20	30
48	48	48	48	48	48	48	0	30	20	30
49	49	49	49	49	49	49	1	30	20	30

Character code							Chr.	Proportional width		
Std.	#437	#850	#860	#861	#863	#865		Normal	Super/Sub	IBM
50	50	50	50	50	50	50	2	30	20	30
51	51	51	51	51	51	51	3	30	20	30
52	52	52	52	52	52	52	4	30	20	30
53	53	53	53	53	53	53	5	30	20	30
54	54	54	54	54	54	54	6	30	20	30
55	55	55	55	55	55	55	7	30	20	30
56	56	56	56	56	56	56	8	30	20	30
57	57	57	57	57	57	57	9	30	20	30
58	58	58	58	58	58	58	:	18	12	30
59	59	59	59	59	59	59	;	18	12	30
60	60	60	60	60	60	60	<	30	20	30
61	61	61	61	61	61	61	=	30	20	30
62	62	62	62	62	62	62	>	30	20	30
63	63	63	63	63	63	63	?	30	20	30
64	64	64	64	64	64	64	@	36	24	30
65	65	65	65	65	65	65	A	36	24	42
66	66	66	66	66	66	66	B	36	24	42
67	67	67	67	67	67	67	C	36	24	42
68	68	68	68	68	68	68	D	36	24	42
69	69	69	69	69	69	69	E	36	24	36
70	70	70	70	70	70	70	F	36	24	36
71	71	71	71	71	71	71	G	36	24	42
72	72	72	72	72	72	72	H	36	24	42
73	73	73	73	73	73	73	I	24	16	24
74	74	74	74	74	74	74	J	30	20	30
75	75	75	75	75	75	75	K	36	24	42
76	76	76	76	76	76	76	L	36	24	36
77	77	77	77	77	77	77	M	42	28	42
78	78	78	78	78	78	78	N	36	24	42
79	79	79	79	79	79	79	O	36	24	42

Character code							Chr.	Proportional width		
Std.	#437	#850	#860	#861	#863	#865		Normal	Super/Sub	IBM
80	80	80	80	80	80	80	P	36	24	36
81	81	81	81	81	81	81	Q	36	24	42
82	82	82	82	82	82	82	R	36	24	42
83	83	83	83	83	83	83	S	36	24	36
84	84	84	84	84	84	84	T	36	24	42
85	85	85	85	85	85	85	U	42	28	42
86	86	86	86	86	86	86	V	36	24	42
87	87	87	87	87	87	87	W	42	28	42
88	88	88	88	88	88	88	X	36	24	42
89	89	89	89	89	89	89	Y	36	24	42
90	90	90	90	90	90	90	Z	30	20	36
91	91	91	91	91	91	91	[24	16	30
92	92	92	92	92	92	92	\	30	20	30
93	93	93	93	93	93	93]	24	16	30
94	94	94	94	94	94	94	^	30	20	30
95	95	95	95	95	95	95	_	30	20	30
96	96	96	96	96	96	96	`	18	12	30
97	97	97	97	97	97	97	a	30	20	30
98	98	98	98	98	98	98	b	36	24	36
99	99	99	99	99	99	99	c	30	20	30
100	100	100	100	100	100	100	d	36	24	36
101	101	101	101	101	101	101	e	30	20	30
102	102	102	102	102	102	102	f	24	16	24
103	103	103	103	103	103	103	g	36	24	36
104	104	104	104	104	104	104	h	36	24	36
105	105	105	105	105	105	105	i	18	12	18
106	106	106	106	106	106	106	j	24	16	18
107	107	107	107	107	107	107	k	36	24	36
108	108	108	108	108	108	108	l	18	12	18
109	109	109	109	109	109	109	m	42	28	42

Character code							Chr.	Proportional width		
Std.	#437	#850	#860	#861	#863	#865		Normal	Super/Sub	IBM
110	110	110	110	110	110	110	n	36	24	36
111	111	111	111	111	111	111	o	30	20	30
112	112	112	112	112	112	112	p	36	24	36
113	113	113	113	113	113	113	q	36	24	36
114	114	114	114	114	114	114	r	30	20	30
115	115	115	115	115	115	115	s	30	20	30
116	116	116	116	116	116	116	t	24	16	24
117	117	117	117	117	117	117	u	36	24	36
118	118	118	118	118	118	118	v	36	24	36
119	119	119	119	119	119	119	w	42	28	42
120	120	120	120	120	120	120	x	30	20	36
121	121	121	121	121	121	121	y	36	24	36
122	122	122	122	122	122	122	z	30	20	30
123	123	123	123	123	123	123	{	24	16	30
124	124	124	124	124	124	124		18	12	30
125	125	125	125	125	125	125	}	24	16	30
126	126	126	126	126	126	126	~	30	20	30
-	127	127	127	127	127	127	◊	30	20	30
128	128	128	128	128	128	128	Ç	36	24	42
129	129	129	129	129	129	129	ü	36	24	36
130	130	130	130	130	130	130	é	30	20	30
131	131	131	131	131	131	131	â	30	20	30
132	132	132	-	132	-	132	ä	30	20	30
133	133	133	133	133	133	133	à	30	20	30
134	134	134	-	134	-	134	â	30	20	30
135	135	135	135	135	135	135	ç	30	20	30
136	136	136	136	136	136	136	ê	30	20	30
137	137	137	-	137	137	137	ë	30	20	30
138	138	138	138	138	138	138	è	30	20	30
139	139	139	-	-	139	139	ï	18	12	18

Character code							Chr.	Proportional width		
Std.	#437	#850	#860	#861	#863	#865		Normal	Super/Sub	IBM
140	140	140	-	-	140	140	î	18	12	18
141	141	141	141	-	-	141	ï	18	12	18
142	142	142	-	142	-	142	Ë	36	24	42
143	143	143	-	143	-	143	Ä	36	24	42
144	144	144	144	144	144	144	É	36	24	36
145	145	145	-	145	-	145	æ	42	28	42
146	146	146	-	146	-	146	Æ	42	28	42
147	147	147	147	147	147	147	ô	30	20	30
148	148	148	-	148	-	148	ö	30	20	30
149	149	149	149	-	-	149	ò	30	20	30
150	150	150	-	150	150	150	û	36	24	36
151	151	151	151	-	151	151	ù	36	24	36
152	152	152	-	-	-	152	ÿ	36	24	36
153	153	153	-	153	-	153	ÿ	36	24	42
154	154	154	154	154	154	154	Ü	42	28	42
155	155	189	155	-	155	-	ϕ	30	20	30
156	156	156	156	156	156	156	£	30	20	30
157	157	190	-	-	-	-	¥	36	24	30
158	158	-	158	158	-	158	ŕ	42	28	42
159	159	159	-	159	159	159	f	30	20	30
160	160	160	160	160	-	160	á	30	20	30
161	161	161	161	161	-	161	í	18	12	18
162	162	162	162	162	162	162	ó	30	20	30
163	163	163	163	163	163	163	ú	36	24	36
164	164	164	164	-	-	164	ñ	36	24	36
165	165	165	165	-	-	165	Ñ	36	24	42
166	166	166	166	-	-	166	ã	30	20	30
167	167	167	167	-	-	167	õ	30	20	30
168	168	168	168	168	-	168	ç	30	20	30
169	169	-	-	169	169	169	ı	30	20	30

Character code							Chr.	Proportional width		
Std.	#437	#850	#860	#861	#863	#865		Normal	Super/Sub	IBM
170	170	170	170	170	170	170	˘	30	20	30
171	171	171	171	171	171	171	½	30	20	30
172	172	172	172	172	172	172	¼	30	20	30
173	173	173	173	173	-	173	ı	30	20	30
174	174	174	174	174	174	174	«	30	20	42
175	175	175	175	175	175	-	»	30	20	42
176	176	176	176	176	176	176	˙	30	30	30
177	177	177	177	177	177	177	˚	30	30	30
178	178	178	178	178	178	178	ˆ	30	30	30
179	179	179	179	179	179	179		30	30	30
180	180	180	180	180	180	180	ı	30	30	30
181	181	-	181	181	181	181	ı	30	30	30
182	182	-	182	182	182	182	ıı	30	30	30
183	183	-	183	183	183	183	ıı	30	30	30
184	184	-	184	184	184	184	ıı	30	30	30
185	185	185	185	185	185	185	ıı	30	30	30
186	186	186	186	186	186	186	ıı	30	30	30
187	187	187	187	187	187	187	ıı	30	30	30
188	188	188	188	188	188	188	ıı	30	30	30
189	189	-	189	189	189	189	ıı	30	30	30
190	190	-	190	190	190	190	ıı	30	30	30
191	191	191	191	191	191	191	ıı	30	30	30
192	192	192	192	192	192	192	ıı	30	30	30
193	193	193	193	193	193	193	ıı	30	30	30
194	194	194	194	194	194	194	ıı	30	30	30
195	195	195	195	195	195	195	ıı	30	30	30
196	196	196	196	196	196	196	-	30	30	30
197	197	197	197	197	197	197	ıı	30	30	30
198	198	-	198	198	198	198	ıı	30	30	30
199	199	-	199	199	199	199	ıı	30	30	30

Character code							Chr.	Proportional width		
Std.	#437	#850	#860	#861	#863	#865		Normal	Super/Sub	IBM
200	200	200	200	200	200	200	⋈	30	30	30
201	201	201	201	201	201	201	⋈	30	30	30
202	202	202	202	202	202	202	⋈	30	30	30
203	203	203	203	203	203	203	⋈	30	30	30
204	204	204	204	204	204	204	⋈	30	30	30
205	205	205	205	205	205	205	=	30	30	30
206	206	206	206	206	206	206	⋈	30	30	30
207	207	-	207	207	207	207	±	30	30	30
208	208	-	208	208	208	208	⋈	30	30	30
209	209	-	209	209	209	209	⋈	30	30	30
210	210	-	210	210	210	210	π	30	30	30
211	211	-	211	211	211	211	⋈	30	30	30
212	212	-	212	212	212	212	⋈	30	30	30
213	213	-	213	213	213	213	F	30	30	30
214	214	-	214	214	214	214	π	30	30	30
215	215	-	215	215	215	215	⋈	30	30	30
216	216	-	216	216	216	216	≠	30	30	30
217	217	217	217	217	217	217	∟	30	30	30
218	218	218	218	218	218	218	∟	30	30	30
219	219	219	219	219	219	219	■	30	30	30
220	220	220	220	220	220	220	■	30	30	30
221	221	-	221	221	221	221	■	30	30	30
222	222	-	222	222	222	222	■	30	30	30
223	223	223	223	223	223	223	■	30	30	30
224	224	-	224	224	224	224	α	30	30	30
225	225	225	225	225	225	225	β	30	30	36
226	226	-	226	226	226	226	Γ	30	30	36
227	227	-	227	227	227	227	π	30	30	36
228	228	-	228	228	228	228	Σ	30	30	42
229	229	-	229	229	229	229	σ	30	30	36

Character code							Chr.	Proportional width		
Std.	#437	#850	#860	#861	#863	#865		Normal	Super/Sub	IBM
230	230	230	230	230	230	230	μ	30	30	36
231	231	-	231	231	231	231	τ	30	30	30
232	232	-	232	232	232	232	Φ	30	30	42
233	233	-	233	233	233	233	θ	30	30	42
234	234	-	234	234	234	234	Ω	30	30	42
235	235	-	235	235	235	235	δ	30	30	30
236	236	-	236	236	236	236	∞	30	30	30
237	237	-	237	237	237	237	∅	30	30	42
238	238	-	238	238	238	238	€	30	30	30
239	239	-	239	239	239	239	∩	30	30	30
240	240	-	240	240	240	240	≡	30	30	30
241	241	241	241	241	241	241	±	30	30	30
242	242	-	242	242	242	242	≥	30	30	30
243	243	-	243	243	243	243	≤	30	30	30
244	244	-	244	244	244	244	∫	30	30	30
245	245	-	245	245	245	245	J	30	30	30
246	246	246	246	246	246	246	÷	30	30	30
247	247	-	247	247	247	247	≈	30	30	30
248	248	248	248	248	248	248	°	30	30	30
249	249	-	249	249	249	249	•	30	30	30
250	250	250	250	250	250	250	•	30	30	30
251	251	-	251	251	251	251	√	30	30	30
252	252	-	252	252	252	252	n	30	30	30
253	253	253	253	253	253	253	²	30	30	30
254	254	254	254	254	254	254	■	30	30	30
255	255	255	255	255	255	255		30	20	30
INT	-	155	-	155	-	155	∅	30	30	42
INT	-	157	-	157	-	157	∅	36	28	42
-	-	158	-	-	-	-	×	42	20	30
INT	-	169	-	-	-	-	®	36	21	30

Character code							Chr.	Proportional width		
Std.	#437	#850	#860	#861	#863	#865		Normal	Super/Sub	IBM
INT	-	181	134	164	-	-	À	36	28	42
-	-	182	143	-	132	-	Á	42	20	42
-	-	183	145	-	142	-	Â	42	28	42
INT	-	184	-	-	-	-	Ã	36	21	30
-	-	198	132	-	-	-	ä	30	20	30
-	-	199	142	-	-	-	Å	42	28	42
INT	-	207	-	-	152	175	à	30	20	30
-	-	208	-	140	-	-	å	36	24	36
-	-	209	-	139	-	-	Ä	42	28	42
-	-	210	137	-	146	-	Ê	36	24	36
-	-	211	-	-	148	-	Ë	36	24	36
-	-	212	146	-	145	-	È	36	24	36
-	-	213	-	-	-	-	É	18	12	18
-	-	214	139	165	-	-	Í	24	16	24
-	-	215	-	-	168	-	İ	24	16	24
-	-	216	-	-	149	-	Ï	24	16	24
-	-	221	-	-	160	-	Ĭ	18	12	30
-	-	222	152	-	-	-	Ī	24	16	24
INT	-	224	159	166	-	-	Ó	30	28	42
-	-	226	140	-	153	-	Ô	30	28	42
-	-	227	169	-	-	-	Õ	30	28	42
-	-	228	148	-	-	-	Ö	30	20	30
-	-	229	153	-	-	-	Ø	30	28	42
-	-	231	-	149	-	-	Þ	30	24	36
-	-	232	-	141	-	-	Ɔ	30	28	42
INT	-	233	150	167	-	-	Ú	30	28	42
-	-	234	-	-	158	-	Û	30	28	42
-	-	235	157	-	157	-	Ü	30	28	42
-	-	236	-	152	-	-	Ý	30	24	36
-	-	237	-	151	-	-	Ÿ	30	28	42

Character code							Chr.	Proportional width		
Std.	#437	#850	#860	#861	#863	#865		Normal	Super/Sub	IBM
-	-	238	-	-	167	-	-	30	20	30
INT	-	239	-	-	161	-	'	18	20	30
-	-	240	-	-	-	-	-	30	20	30
-	-	242	-	-	-	-	=	30	20	30
-	-	243	-	-	173	-	≈	30	21	30
-	-	244	-	-	134	-	¶	30	20	30
-	-	245	-	-	143	-	§	30	20	30
-	-	247	-	-	165	-	˙	30	20	30
INT	-	249	-	-	164	-	ˆ	30	20	30
-	-	251	-	-	-	-	ˆ	30	20	30
-	-	252	-	-	166	-	ˆ	30	20	30
-	-	-	-	-	141	-	=	30	20	30
INT	-	-	-	-	-	-	ˆ	30	20	30
INT	-	-	-	-	-	-	°	24	16	24
INT	-	-	-	-	-	-	W	42	28	42
INT	-	-	-	-	-	-	†	30	20	30
INT	-	-	-	-	-	-	β	36	24	36
INT	-	-	-	-	-	-	™	36	24	36

INDEX

A

Absolute horizontal tab, 108
Adjustment lever, 3, 21
AEC mode, 4, 51
All reset, 43
Application software, 18
ASF control commands, 119-120
Auto emulation change mode, 4, 51
Auto Line Feed, 51, 105
Auto loading position, 42
Automatic Sheet Feeder, 11, 51, 65

B

Backspace, 105
Bail lever, 3, 25, 27, 29
Base unit for line spacing, 97
Beep tones, 47
Bell command, 118
Bi-directional printing, 51, 118
Bit image dot-matrix, 144
Bottom feed, 19, 22, 145
Bottom margin, 100
Buffer size, 145
Button and indicator functions, 31-34

C

Cancel command, 117
Carriage centering, 54
Carriage return, 105
Carton contents, 10
Cartridge slot, 3
Center text, 106
Character data, 122
Character dot pattern, 127
Character height, 95
Character matrix, 121, 124, 127, 144

Character pitch commands, 90-95
Character set #1, 87, 160
Character set #2, 87
Character set commands, 87-89
Character set table, 149-161
Character size commands, 90-95
Character space, 123
Character spacing, 5, 93
Character table, 53
Character width, 93, 95
Clamp lever, 3, 24
Clear the buffer, 43
Code page, 53, 88, 144, 153-159
 #437, 153-154
 #850, 155
 #860, 156
 #861, 157
 #863, 158
 #865, 159
Command summary, 177-181
Component, 2-3
Compression mask bit, 127
Condensed printing, 90
Contents of the carton, 10
Control commands, 81-120
Control panel, 3, 5, 31-44
Copy characters, 115

D

Default settings, 49-55
Define download characters, 113, 114
Delete command, 117
Dimensions, 146
Display messages, 45-46
DOS commands, 133
Dot Adjustment mode, 38
Double-density graphics, 109

Double-height characters, 94
Double-size characters, 94
Double-strike printing, 84
Download, 51
Download character commands,
113-116
Download character set, 126
Download characters, 121-131, 144
Draft, 1, 143

E

EDS mode, 5, 18, 49, 50
EDS setting, 55
EJECT/PARK button, 33
Electronic DIP Switch mode, 5, 18, 49,
50
Elite pitch, 90
Emphasized printing, 83
Emulation, 18, 51, 146
Entry slot, 3
Expanded printing, 92

F

Factory settings, 49
Fanfold forms, 1, 19, 145
Fanfold forms, loading, 22-27
Fanfold forms, paper path, 22
Features, 4-5
Font, 1, 11, 75, 143
FONT button, 34
Font Cartridge, 1, 11, 75, 143
Font control commands, 82-86
Font lock mode, 5, 37
Font selection, 54
Font style, 6-7, 82, 143
Font style commands, 82-86
Form feed, 41, 101
Forward feed, 98
Forward micro-feed, 42
Friction feed, 145
Front cover, 3, 13, 15

Full justify, 106

G

Graphics commands, 109-112
Graphics direction, 51
Graphics mode, 111
Graphics printing, 5

H

Hex-density graphics, 110
Hexadecimal dump, 40
High Speed Draft, 1, 143
Horizontal position commands,
104-108
Horizontal tab, 106, 107
Horizontal tab stops, 106
HS Draft, 1, 143

I

IBM character set, 87, 153-159
IBM code page, 53, 88, 144, 153-159
#437, 153-154
#850, 155
#860, 156
#861, 157
#863, 158
#865, 159
Index table data, 129
Initial condition, 120
Interface, 146
Interface connector, 3, 17
Interface converter, 3
International character set, 53, 88, 144,
152
Italic characters, 83

J

Justification, 106

L

Lables, 1, 19
LCD, 1, 5
Left justify, 106
Left margin, 104, 105
Letter Quality, 143
Line feed, 98
Line spacing, 95, 96, 97, 143
Loading fanfold forms, 22-27, 73
Loading single sheets, 28-30, 68
Locating the printer, 9
Long test mode, 36
LQ, 143

M

Macro definition, 43
Maintenance, 64
Master print mode, 93
Most significant bit, 117
MS-DOS, 133
MSB, 117
Multi-part forms, 1, 5, 19
Mute cover, 3, 16, 23

N

Normal-density graphics, 109
Number of columns, 144

O

Off line command, 118
ON LINE button, 32
On line command, 118
One-time line feed, 99
One-time reverse feed, 99
Optional accessories, 11, 65-79, 146
Ornament character, 85
Other printer commands, 117-120
Overlining, 84, 85

P

Page length, 53, 100

Paper feed, 145
PAPER FEED button, 32
Paper feed speed, 145
Paper feed trouble, 59
Paper guide, 3, 16
Paper parking, 1, 5, 26
Paper path
 Fanfold forms, 22
 Single sheets, 28
Paper specifications, 145
Paper-out detector, 52, 101
Pica pitch, 90
Pinout of interface connector, 147-148
PITCH button, 33
Pitch commands, 90-95
Pitch lock mode, 5, 37
Platen knob, 3, 12
Power supply trouble, 57
Power switch, 3
Print area, 20, 52
Print area test mode, 37
Print direction, 143
Print head, 3, 143
Print head shield, 14
Print mode, 52
Print quality, 82
Print styles, 5
Printer features, 4-5
Printer initialize, 43
Printer placement, 9
Printing gap, 21
Printing speed, 143
Printing trouble, 57-63
Proportional spacing, 91
Proportional spacing table, 162-172
Pull Tractor Unit, 11, 71-74
Push tractor feed, 145

Q

Quadruple size characters, 94
Quadruple-density graphics, 110

Quiet mode, 5, 32

R

RAM Cartridge, 11, 75
RAM usage, 51
Rear cover, 3, 23
Relative horizontal tab, 107, 108
Release lever, 3, 23
Reset all tab stops, 107
Reset printer, 120
Reverse feed, 98
Reverse line feed, 98
Reverse micro-feed, 42
Ribbon cartridge, 3, 5, 14, 146
Right justify, 106
Right margin, 104, 105

S

Sample program, 124-125, 130-131, 136-140
Score, 85
Selection of paper, 19-20
Self-test, 35, 36
Semi-condensed, 90
Serial-Parallel Converter, 11, 78
Setting up, 12-18
Shift download character area, 116
Short test mode, 35
Single sheets, 1, 19, 28-30, 145
Special character set, 161
Specifications, 143-146
Standard character set, 87, 150-151
Strike-through, 85
Subscript, 86
Superscript, 85
Switch combination functions, 41-44

T

Tear assist, 13
Tear-off function, 5, 27
Top of form, 41, 99

Tractor, 3
Troubleshooting, 57-63

U

Underlining, 84, 85
Uni-directional printing, 51, 119
Unpacking and inspection, 10

V

Vertical position commands, 96-103
Vertical tab, 103
Vertical tab channel, 102
Vertical tab stops, 102

W

Weight, 146

Z

Zero style, 89

COMMAND SUMMARY

Standard Mode

The following commands take effect with the Standard mode.

CONTROL CODE	FUNCTION	PAGE
<BEL>	Bell	118
<BS>	Backspace	105
<HT>	Horizontal tab	107
<LF>	Line feed	98
<VT>	Vertical tab	103
<FF>	Form feed	101
<CR>	Carriage return	105
<SO>	Expanded printing for one line	92
<SI>	Condensed printing	90
<DC1>	Set printer on-line	118
<DC2>	Cancel condensed printing	91
<DC3>	Set printer off-line	118
<DC4>	Cancel one-line expanded printing	92
<CAN>	Cancel last line	117
<ESC> <LF>	Reverse line feed	98
<ESC> <FF>	Return to top of current page	101
<ESC> <SO>	Expanded printing for one line	92
<ESC> <SI>	Condensed printing	90
<ESC> <0>	Manual feed	119
<ESC> <4>	Auto feed	119
<ESC> "R"	Eject paper from ASF	119
<ESC> "T" <i>n</i>	Set print start position on ASF	120
<ESC> <SP> <i>n</i>	Increase character spacing	93
<ESC> "!" <i>n</i>	Select master print mode	93
<ESC> "#"	Accept MSB as is	117
<ESC> "\$" <i>n1 n2</i>	Absolute horizontal tab in inches	108
<ESC> "%" 0	Select ROM character set	116
<ESC> "%" 1	Select download character set	116
<ESC> "&" <0> <i>n1 n2 m0 m1 m2 d1 d2 ... dx</i>	Define download characters	113
<ESC> "(" "-" <3> <0> <1> <i>n1 n2</i>	Select score	85
<ESC> "*" <i>n0 n1 n2 m1 m2 ...</i>	Select graphics mode	111
<ESC> "+" <i>n</i>	Set line spacing to <i>n</i> /360 inch	96
<ESC> "-" <i>n</i>	Underlining	84
<ESC> "f" <i>n0</i>	Select vertical tab channel	102
<ESC> "0"	Set line spacing to 1/8 inch	96
<ESC> "1"	Set line spacing to 7/60 inch	96
<ESC> "2"	Set line spacing to 1/6 inch	96
<ESC> "3" <i>n</i>	Set line spacing to <i>n</i> /180 inch	97
<ESC> "4"	Select italic characters	83
<ESC> "5"	Select upright characters	83
<ESC> "6"	Select character set #2	87
<ESC> "7"	Select character set #1	87
<ESC> "8"	Disable paper-out detector	101
<ESC> "9"	Enable paper-out detector	101
<ESC> ":" <0> <i>n</i> <0>	Copy character set from ROM into RAM	115
<ESC> "<"	One-line uni-directional printing	119
<ESC> "="	Set MSB to 0	117

CONTROL CODE	FUNCTION	PAGE
<ESC> ">"	Set MSB to 1	117
<ESC> "?" <i>n m</i>	Convert graphics density	112
<ESC> "@"	Reset printer	120
<ESC> "A" <i>n</i>	Set line spacing to <i>n</i> /60 inch	97
<ESC> "B" <i>n1 n2</i> <0>	Set vertical tab stops	102
<ESC> "C" <0> <i>n</i>	Set page length to <i>n</i> inches	100
<ESC> "C" <i>n</i>	Set page length to <i>n</i> lines	100
<ESC> "D" <i>n1 n2</i> <0>	Set horizontal tab stops	106
<ESC> "E"	Emphasized printing	83
<ESC> "F"	Cancel emphasized printing	83
<ESC> "G"	Double-strike printing	84
<ESC> "H"	Cancel double-strike printing	84
<ESC> "J" <i>n</i>	Perform one <i>n</i> /180-inch line feed	99
<ESC> "K" <i>n1 n2 m1 m2</i> ...	Print normal-density 8-bit graphics	109
<ESC> "L" <i>n1 n2 m1 m2</i> ...	Print double-density 8-bit graphics	109
<ESC> "M"	Elite pitch	90
<ESC> "N" <i>n</i>	Set bottom margin	100
<ESC> "O"	Cancel bottom margin	100
<ESC> "P"	Pica pitch	90
<ESC> "Q" <i>n</i>	Set right margin	104
<ESC> "R" <i>n</i>	Select international character set	88
<ESC> "S" 0	Superscript	85
<ESC> "S" 1	Subscript	86
<ESC> "T"	Cancel superscript or subscript	86
<ESC> "U" 0	Bi-directional printing	118
<ESC> "U" 1	Uni-directional printing	119
<ESC> "W" <i>n</i>	Expanded printing	92
<ESC> "Y" <i>n1 n2 m1 m2</i> ...	Print double-density, double-speed 8-bit graphics	109
<ESC> "Z" <i>n1 n2 m1 m2</i> ...	Print quadruple-density 8-bit graphics	110
<ESC> "I" "T" <4> <0> <0> <0> <i>n1 n2</i>	Select IBM code page	88
<ESC> "v" <i>n1 n2</i>	Relative horizontal tab	107
<ESC> "a" 0	Left justify	106
<ESC> "a" 1	Center text	106
<ESC> "a" 2	Right justify	106
<ESC> "a" 3	Full justify	106
<ESC> "b" <i>n0 n1 n2</i> <0>	Set vertical tab stops in channel	102
<ESC> "e" 0 <i>n</i>	Set horizontal tab stop every <i>n</i> columns	107
<ESC> "e" 1 <i>n</i>	Set vertical tab stops every <i>n</i> lines	102
<ESC> "f" 0 <i>n</i>	Absolute horizontal tab in columns	108
<ESC> "f" 1 <i>n</i>	Feed paper <i>n</i> lines	99
<ESC> "g"	Semi-condensed pitch	90
<ESC> "h" <i>n</i>	Select double or quadruple size	94
<ESC> "j" <i>n</i>	Perform one <i>n</i> /180-inch reverse line feed	99
<ESC> "k" <i>n</i>	Select LQ font	82
<ESC> "l" <i>n</i>	Set left margin	104
<ESC> "p" <i>n</i>	Proportional spacing	91
<ESC> "q" <i>n</i>	Select ornament character	85
<ESC> "r" 0	Select standard character set	87
<ESC> "r" 1	Select IBM character set	87
<ESC> "r" 2	Shift download character area	116
<ESC> "w" 0	Return to normal height	94
<ESC> "w" 1	Print double-height characters	94
<ESC> "x" <i>n</i>	Select <i>print quality</i>	82
<ESC> "~" 0	Select normal zero	89
<ESC> "~" 1	Select slash zero	89
<FS> "3" <i>n</i>	Set line spacing to <i>n</i> /360 inch	96
<FS> "@"	Reset printer	120
<FS> "E" <i>n</i>	Select character width	93
<FS> "F"	Select forward feed mode	98
<FS> "I" 0	Select standard character set	87

CONTROL CODE	FUNCTION	PAGE
<FS> "I" 1	Select IBM character set	87
<FS> "I" 2	Shift download character area	116
<FS> "R"	Select reverse feed mode	98
<FS> "V" 0	Return to normal height	94
<FS> "V" 1	Print double-height characters	94
<FS> "Z" <i>n1 n2 m1 m2 m3 ...</i>	Print hex-density 24-bit graphics	110
<FS> "A" <i>n1 n2</i>	Enable printing of all character codes	89
<FS> "A" <i>n</i>	Enable printing of all character codes on next character	89
	Delete last character sent	117

IBM Mode

The following commands take effect with the IBM mode.

CONTROL CODE	FUNCTION	PAGE
<BEL>	Bell	118
<BS>	Backspace	105
<HT>	Horizontal tab	107
<LF>	Line feed	98
<VT>	Vertical tab	103
<FF>	Form feed	101
<CR>	Carriage return	105
<SO>	Expanded printing for one line	92
<SI>	Condensed printing	90
<DC1>	Set printer on-line	118
<DC2>	Pica pitch	90
<DC4>	Cancel one-line expanded printing	92
<CAN>	Cancel last line	117
<ESC> <SO>	Expanded printing for one line	92
<ESC> <SI>	Condensed printing	90
<ESC> <0>	Manual feed	119
<ESC> <4>	Auto feed	119
<ESC> "R"	Eject paper from ASF	119
<ESC> "T" <i>n</i>	Set print start position on ASF	120
<ESC> "-" <i>n</i>	Underlining	84
<ESC> "0"	Set line spacing to 1/8 inch	96
<ESC> "1"	Set line spacing to 7/72 inch	96
<ESC> "2"	Execute <ESC> "A"	98
<ESC> "3" <i>n</i>	Set line spacing to <i>n</i> /180 inch, <i>n</i> /216 inch, or <i>n</i> /360 inch	97
<ESC> "4"	Set top of page at current position	99
<ESC> "5" <0>	Cancel automatic line feed	105
<ESC> "5" <1>	Set automatic line feed	105
<ESC> "6"	Select character set #2	87
<ESC> "7"	Select character set #1	87
<ESC> "8"	Disable paper-out detector	101
<ESC> "9"	Enable paper-out detector	101
<ESC> ":"	Elite pitch	90
<ESC> "=" <i>n1 n2 "# n3 n4 <0> n5 m1 m2 ... m9 d1 d2 ... dx</i>	Define download characters	114
<ESC> "@"	Reset printer	120
<ESC> "A" <i>n</i>	Set line spacing to <i>n</i> /72 inch	97
<ESC> "B" <i>n1 n2 <0></i>	Set vertical tab stops	102
<ESC> "C" <0> <i>n</i>	Set page length to <i>n</i> inches	100
<ESC> "C" <i>n</i>	Set page length to <i>n</i> lines	100
<ESC> "D" <i>n1 n2 <0></i>	Set horizontal tab stops	106
<ESC> "E"	Emphasized printing	83
<ESC> "F"	Cancel emphasized printing	83
<ESC> "G"	Double-strike printing	84
<ESC> "H"	Cancel double-strike printing	84
<ESC> "I" <i>n</i>	Select font and pitch	92
<ESC> "J" <i>n</i>	Perform one <i>n</i> /180-inch, <i>n</i> /216-inch, or <i>n</i> /360-inch line feed	99
<ESC> "K" <i>n1 n2 m1 m2 ...</i>	Print normal-density 8-bit graphics	109
<ESC> "L" <i>n1 n2 m1 m2 ...</i>	Print double-density 8-bit graphics	109
<ESC> "N" <i>n</i>	Set bottom margin	100
<ESC> "O"	Cancel bottom margin	100
<ESC> "P" <i>n</i>	Proportional spacing	91
<ESC> "Q" <i>n</i>	Set printer off-line	118
<ESC> "R"	Reset all tab stops	107
<ESC> "S" 0	Superscript	85

CONTROL CODE	FUNCTION	PAGE
<ESC> "S" 1	Subscript	86
<ESC> "T" 1	Cancel superscript or subscript	86
<ESC> "U" 0	Bi-directional printing	118
<ESC> "U" 1	Uni-directional printing	119
<ESC> "W" n	Expanded printing	92
<ESC> "X" n1 n2	Set left and right margins	105
<ESC> "Y" n1 n2 m1 m2 ...	Print double-density, double-speed 8-bit graphics	109
<ESC> "Z" n1 n2 m1 m2 ...	Print quadruple-density 8-bit graphics	110
<ESC> "I" "@< <4> <0> <0> <0> <0>	n m Select character height, width, and line spacing	95
<ESC> "I" "I" <2> <0> n1 n2	Select font and pitch	91
<ESC> "I" "K" <3> <0> <0> n1 n2	Select initial conditions	120
<ESC> "I" "T" <4> <0> <0> <0> n1 n2	Select IBM code page	88
<ESC> "I" "V" <4> <0> <0> <0> n1 n2	Set base unit for line spacing	97
<ESC> "I" "d" <1> <0> n	Select print quality	82
<ESC> "I" "g" n1 n2 m0 m1 m2 ...	Select graphics mode	111
<ESC> "W" n1 n2	Enable printing of all character codes	89
<ESC> "J" n	Reverse line feed	98
<ESC> "A" n	Enable printing of all character codes on next character	89
<ESC> " " n	Overlining	84
<ESC> "d" n1 n2	Relative horizontal tab in inches	108
<ESC> "j" n	Stop printing	118
<ESC> "k" n	Select LQ font	82
<ESC> "r" 0	Select standard character set	87
<ESC> "t" 1	Select IBM character set	87

Consumer Response

Star Micronics Co., Ltd. invites your suggestions and comments on your printer and this manual. Please address your correspondence to:

Worldwide Headquarters:

STAR MICRONICS CO., LTD.
20-10 Nakayoshida
Shizuoka, JAPAN 422-91
Attn: Product Manager

American Market:

STAR MICRONICS AMERICA, INC.
420 Lexington Avenue, Suite 2702-25
New York, NY 10170
Attn: Product Manager

European Market:

STAR MICRONICS DEUTSCHLAND GMBH
Westerbachstraße 59
P.O. Box 940330
D-6000 Frankfurt/Main 90
F.R. of Germany
Attn: Product Manager

U.K. Market:

STAR MICRONICS U.K., LTD.
Star House
Peregrine Business Park
Gomm Road, High Wycombe
Bucks. HP13 7DL, U.K.
Attn: Product Manager

French Market:

STAR MICRONICS FRANCE S.A.R.L.
25, rue Michaël Faraday
78180 Montigny-le-Bretonneux
Attn: Product Manager

Asian Market:

STAR MICRONICS ASIA LTD.
Room 2408-10 Sincere Building;
173 Des Voeux Road, Central, HONG KONG
Attn: Product Manager

CONTROL PANEL OPERATIONS

The control panel buttons can be pressed individually to perform the operations indicated by their names.

LCD DISPLAY — shows the information of the printer status.

FONT BUTTON — selects the font to be printed. To change the font, set the printer off-line, then press the FONT button repeatedly until the message on the display illuminates.

PITCH BUTTON — allows you to select the printing pitch. Remember that the printer must be off-line for you to do this.

EJECT/PARK BUTTON — Pressing this button parks the fanfold forms or ejects the cut sheet paper.

PAPER FEED BUTTON — If you press this button while off-line, the paper will feed forward. If you hold the button down, the printer will perform consecutive line feeds.

If you press this button while on-line, this will alternately flash the "QUIET" message on the

display. When in Quiet mode with the "QUIET" message, the printer will print slightly slower, but at a reduced noise level.

ON LINE BUTTON — sets the printer on-line and off-line. The status changes each time you press the button.

POWER-UP FUNCTIONS

The control panel buttons have special functions that operate if you hold them down while switching power on.

SELF-TEST

If the printer is turned on while the **ON LINE** button is pressed, the printer will enter the short self-test mode, with the "P1" message on the display.

If the printer is turned on while the **PAPER FEED** button is pressed, the printer will enter the long self-test mode, with the "P2" message on the display.

PRINT AREA TEST

By holding the **EJECT/PARK** button down during power-up, the printer will enter the print area test mode, with the "P3" message on the display. This way, you can find how many lines on your paper are available for printing.

PITCH LOCK

By holding the **PITCH** button down during power-up, the print pitch can only be selected from the control panel. This prevents software interference. You will hear an acknowl-

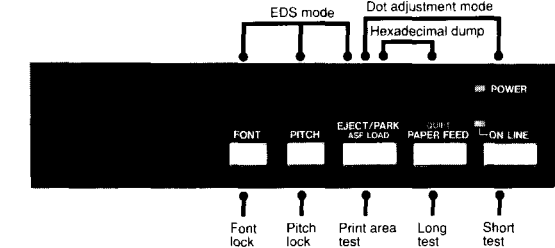

edging beep, and the printer will show the "P-LOCK" message on the display as power comes on.

FONT LOCK

By holding the **FONT** button during power-up, fonts can only be selected from the control panel. This prevents software interference.

There will be an acknowledging beep and "F-LOCK" message on the display.

HEXADECIMAL DUMP

In this mode, all data received will be printed in a hexadecimal dump format, rather than the control codes being acted on as command codes.

SWITCH COMBINATION FUNCTIONS

Several additional functions can be obtained by pressing the control panel buttons with the off-line state.

FORM FEED

If you are using cut forms, this operation ejects the current page. If you are using fanfold forms, it feeds to the top of the next page.

TOP OF FORM

When you power on the printer, the top-of-form position is automatically set to the current position. If this is not where you want the top of the page to be, you can change the top-of-form position.

MICRO-FEED

For fine alignment, you can feed the paper either forward or reverse in very small increments.

BUFFER CLEAR/ALL RESET

Turning power off is one way to clear the buffer, but there is another way.

Press and hold the **ON LINE** and **FONT** button in off-line. The "bc" message shows on display signaling that the buffer has been

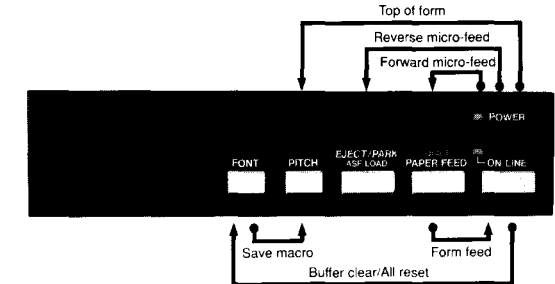

cleared. If you hold these buttons more three seconds, you will hear three beep tones and the printer will be initialized to the power-on default settings.

SAVE MACRO

You can store the current settings to the printer for later use with the **FONT** button and the **PITCH** button combinations.

USERS' GUIDE



BAIL LEVER FUNCTIONS

The bail lever is used to control paper.

If the paper is not mounted on the printer, use the bail lever to load the paper.

When you open the bail lever with the fanfold paper in on-line, the printer goes off-line and the bail lever automatically closed, then the printer also feeds the paper forward. This allows you to cut it off just below the last line printed.

When you open the bail lever again, the paper feeds backward stopping where you left off, and the printer returns to on-line.

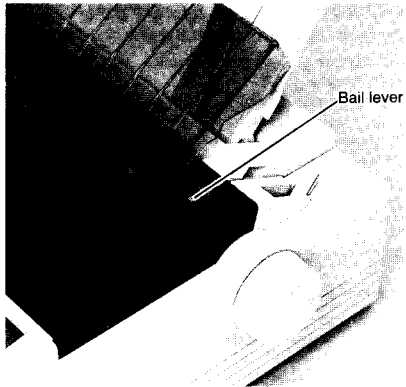

EDS MODE

From the control panel you can change the parameters that define how your printer works. This function is called the Electronic DIP Switch (EDS) mode.

The EDS mode has 16 functions you can set as the power-on default.

Turn the printer on while simultaneously holding the **FONT**, **PITCH** and **EJECT/PARK** buttons.

The "EDS" message will show on the display, and enter the EDS mode.

In EDS mode, the buttons on the control panel are used as shown below:

- Use the **FONT** button to select the Bank Letter.
- Use the **PITCH** button to select the Switch Number.
- The LCD display on the control panel shows the current setting. Use the **EJECT/PARK** button to change the settings.
- Press the **PAPER FEED** button to print the current settings.
- Press the **ON LINE** button to exit the EDS mode.

Number	Function	ON	OFF
A-1	Emulation	STANDARD/EPSON	IBM
A-2	AEC Mode	Enabled	Disabled
A-3	RAM Usage	Input Buffer	Download Buffer
A-4	Auto LF with CR	Disabled	Enabled
A-5	Auto Sheet Feeder	Not installed	Installed
A-6	Graphics Direction	Bi-directional	Uni-directional
B-1	(Not used)		
B-2	Paper-cut	Enabled	Disabled
B-3	(Not used)		
B-4	(Reserved)	Leave ON	
B-5	Printable Area	Type A	Type B
B-6	(Not used)		
C-1			
C-2	Print Mode	(See table 1)	
C-3			
C-4	Page Length	(See table 2)	
C-5			
D-1	Character Table (Standard mode) (IBM mode)	Graphics Set #2	Italics Set #1
D-2	IBM Code page or International	(See table 3 and 4)	
D-4	Character Set		
D-5	CR Centring	Disabled	Enabled
E-1			
E-2			
E-3	LO Font Selection	(See table 5)	
E-4			
E-5			
F-1	EDS Setting	Current	Reset

NOTE: The factory default is the "ON" position for all functions except A-6 which is set to the "OFF" position.

Table 1

Print Mode	C-1	C-2
10CPI DRAFT	ON	ON
10CPI HS DRAFT	ON	OFF
17CPI DRAFT	OFF	ON
10CPI LO	OFF	OFF

Table 2

Page Length	C-3	C-4	C-5
11 inches/Letter	ON	ON	ON
8 inches	OFF	ON	ON
11.7 inches/A4	ON	OFF	ON
12 inches	OFF	OFF	ON
8.5 inches/Letter	ON	ON	OFF
14 inches/Legal	OFF	ON	OFF
10.5 inches/Executive	ON	OFF	OFF
7.25 inches/Executive	OFF	OFF	OFF

Table 3

IBM Code Page	D-2	D-3	D-4	IBM Code Page	D-2	D-3	D-4
#437 U.S.A.	ON	ON	ON	#863 Canadian French	ON	ON	OFF
#850 Multi-lingual	OFF	ON	ON	#865 Nordic	OFF	ON	OFF
#860 Portuguese	ON	OFF	ON	(Reserved)	ON	OFF	OFF
#861 Icelandic	OFF	OFF	ON	(Reserved)	OFF	OFF	OFF

Table 4

Country	D-2	D-3	D-4	Country	D-2	D-3	D-4
U.S.A.	ON	ON	ON	Denmark I	ON	ON	OFF
France	OFF	ON	ON	Sweden	OFF	ON	OFF
Germany	ON	OFF	ON	Italy	ON	OFF	OFF
England	OFF	OFF	ON	Spain I	OFF	OFF	OFF

Table 5

Font Name	E-1	E-2	E-3	E-4	E-5	Font Name	E-1	E-2	E-3	E-4	E-5
Roman	ON	ON	ON	ON	ON	LPC/EAN	ON	ON	ON	ON	OFF
Sansserif	OFF	ON	ON	ON	ON	Old-Style	OFF	ON	ON	ON	OFF
Courier	ON	OFF	ON	ON	ON	Firenze	ON	OFF	ON	ON	OFF
Prestige	OFF	OFF	ON	ON	ON	(Reserved)	OFF	OFF	ON	ON	OFF
Script	ON	ON	OFF	ON	ON	(Reserved)	ON	ON	OFF	ON	OFF
OCR-B	OFF	ON	OFF	ON	ON	(Reserved)	OFF	ON	OFF	ON	OFF
OCR-A	ON	OFF	OFF	ON	ON	(Reserved)	ON	OFF	OFF	ON	OFF
Orator	OFF	OFF	OFF	ON	ON	(Reserved)	OFF	OFF	OFF	ON	OFF
Orator 2	ON	ON	ON	OFF	ON	SLQ Roman	ON	ON	ON	OFF	OFF
TW-Light	OFF	ON	ON	OFF	ON	SLQ TW-Light	OFF	ON	ON	OFF	OFF
Letter-Gothic	ON	OFF	ON	OFF	ON	SLQ Script	ON	OFF	ON	OFF	OFF
Blippo	OFF	OFF	ON	OFF	ON	(Reserved)	OFF	OFF	ON	OFF	OFF
H-Gothic	ON	ON	OFF	OFF	ON	(Reserved)	ON	ON	OFF	OFF	OFF
Orane	OFF	ON	OFF	OFF	ON	(Reserved)	OFF	ON	OFF	OFF	OFF
Cinema	ON	OFF	OFF	OFF	ON	(Reserved)	ON	OFF	OFF	OFF	OFF
Code 39	OFF	OFF	OFF	OFF	ON	(Reserved)	OFF	OFF	OFF	OFF	OFF

PRINTED IN JAPAN